



THE UNITED REPUBLIC OF TANZANIA  
MINISTRY OF EDUCATION, SCIENCE AND TECHNOLOGY  
NATIONAL EXAMINATIONS COUNCIL OF TANZANIA



STUDENTS' ITEMS RESPONSE ANALYSIS  
REPORT ON THE FORM TWO NATIONAL ASSESSMENT  
(FTNA), 2023

ENGINEERING DRAWING



**THE UNITED REPUBLIC OF TANZANIA**  
**MINISTRY OF EDUCATION, SCIENCE AND TECHNOLOGY**  
**NATIONAL EXAMINATIONS COUNCIL OF TANZANIA**



**STUDENTS' ITEMS RESPONSE ANALYSIS**  
**REPORT ON THE FORM TWO NATIONAL**  
**ASSESSMENT (FTNA), 2023**

**091 ENGINEERING DRAWING**

Published by  
National Examinations Council of Tanzania,  
P.O. Box 2624,  
Dar es Salaam, Tanzania.

© The National Examinations Council of Tanzania, 2024

All rights reserved.

## TABLE OF CONTENTS

FOREWORD.....	iv
1.0 INTRODUCTION .....	1
2.0 ITEM RESPONSE ANALYSIS IN EACH QUESTION.....	2
2.1 Section A: Short Answer Questions .....	2
2.2.1 Question 1: Scale and Similar Figures .....	2
2.2.2 Question 2: Free Hand Sketching .....	7
2.2.3 Question 3: Construction of Geometric Figures .....	10
2.2.4 Question 4: Symbol, Abbreviation and Dimensioning .....	14
2.2 Section B: Short Answer Questions.....	19
2.2.1 Question 5: Free Hand Sketching and Pictorial drawing .....	19
2.2.2 Question 6: Pictorial Drawing .....	22
2.2.3 Question 7: Pictorial Drawing and Dimensioning .....	26
3.0 ANALYSIS OF STUDENTS' PERFORMANCE IN EACH TOPIC.....	29
4.0 CONCLUSION AND RECOMMENDATIONS .....	30
4.1 Conclusion .....	30
4.2 Recommendations.....	30
4.2.1 Recommendations to Students .....	30
4.2.2 Recommendations to Teachers .....	31
Appendix I: A Summary of Students' Performance (Question-Wise) in Engineering Drawing, 2023 .....	32
Appendix II: Students' performance Grade-wise in 2023 in Comparison 2022 ..	33

## FOREWORD

This report presents Students' Items Response Analysis (SIRA) in Form Two National Assessment in Engineering Drawing subject which was conducted in November, 2023. The report aims to provide feedback to all educational stakeholders on the factors that contributed to the students' performance in Engineering Drawing subject.

The Form Two National Assessment (FTNA) is a formative evaluation which intends to monitor students' learning and provide feedback that teachers, students and other educational stakeholders can use to improve teaching and learning processes. The analysis reveals that, the assessed students had good performance. The given performance was noted in sub-topics such as *Construction of Geometric Figures* and *Free Hand Sketching*. In addition, the assessed students had average performance in sub-topic, *Pictorial Drawings* and *Dimensioning, Symbols and Abbreviation*. The good and average performance of the students was contributed by numerous factors. Some of these factors are understanding of the questions' demands and adequate knowledge and skills on some tested subject matters. On the other hand, the students' performance was poor in sub-topic of *Scale and Similar Figures*. The students' poor performance was contributed by factors such as failure to understand the requirements of the questions, lack of knowledge and skills on interpreting the given problem into solution.

The analysis of the students' performance helps to identify students' strengths and weaknesses for future improvement in their learning before sitting for Certificate of Secondary Education Examination (CSEE). It also identifies challenging areas for taking appropriate measures to improve teaching and learning process.

The National Examinations Council of Tanzania (NECTA) expects that, the feedback provided in this report will enable the education stakeholders to take appropriate measures in improving teaching and learning of Engineering Drawing subject. Consequently, students will acquire knowledge, skills and competence indicated in the syllabus for better performance in future assessments and examinations.

The Council profoundly appreciates all the people who prepared this report to its completion.



Dr. Said A. Mohamed  
**EXECUTIVE SECRETARY**

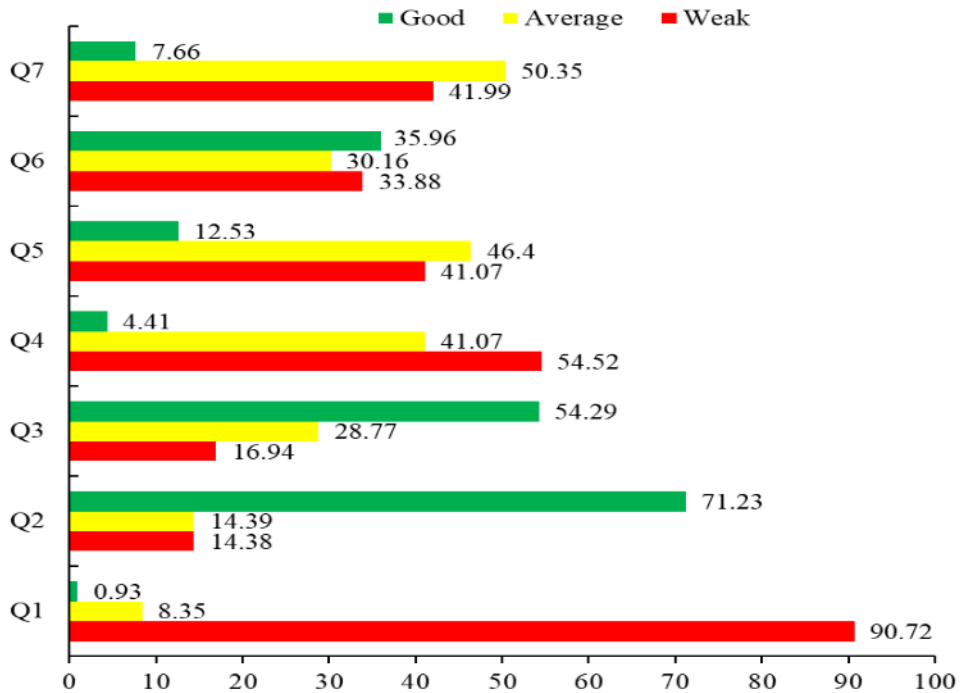
## 1.0 INTRODUCTION

This report presents students' performance on Form Two National Assessment (FTNA) in Engineering Drawing subject which was administered in November, 2023. The assessment focused on the students' competences as per the current Form I and II Engineering Drawing Syllabi of 2019. The report shows students' performance question-wise by identifying the students' strengths and weaknesses in each question attempted.

The analysis shows that, the general performance in Engineering Drawing FTNA 2023 was good because 317 (73.55%) students passed. The students' performance in grades was as follows: A-12 (2.78%), B-50 (11.60%), C-142 (32.95%) and D-113 (26.22%). However, 114 (26.45%) students failed by scoring grade F. The 2023 students' performance has increased by 0.69 per cent when compared to the result of 2022 Engineering Drawing FTNA in which 349 (72.86%) students passed out of 479 students who sat for the paper.

The Engineering Drawing assessment paper had seven questions which were divided into two sections, A and B. Section A comprised of four short answer questions, each carrying 10 marks. Section B consisted of three questions, each carrying 20 marks. The students were required to answer all the questions in all sections. The performance analysis of students in all sections was done based on the analysis of responses in each question.

The performance of the students in this report is grouped into three categories which are poor, average and good. The categories are based on the percentages of students who scored above average in range of 0-29, 30-64 and 65-100 marks respectively. This given performance is presented in figures and tables using colours, whereby red, yellow and green colours are used to represent weak, average and good performance respectively. Figure 1 shows overall performance of 431 students who sat for Engineering Drawing assessment in November, 2023.



**Figure 1:** The overall performance of students who sat for Engineering Drawing assessment

## 2.0 ITEM RESPONSE ANALYSIS IN EACH QUESTION

This part addresses the performance of the students based on the scores obtained in each question. It covers the type of questions, topic from which the questions were constructed and the competencies tested. The requirements of each question and the percentages of the students who had weak, average and good performance based on their responses in each question is presented.

### 2.1 Section A: Short Answer Questions

Section A had four questions, each question weighing 10 marks making a total of 40 marks. The questions were extracted from the topics of Engineering Drawing I and Engineering Drawing II. Specifically, the given questions were prepared from sub-topics of *Scale, Similar Figures and Construction of Geometric Figures* found in Engineering Drawing I. On the other hand, the sub-topics which were drawn from Engineering Drawing II are *Dimensioning, Free Hand Sketching and Symbols and Abbreviation*. Students were required to answer all the questions in this section.

#### 2.2.1 Question 1: Scale and Similar Figures

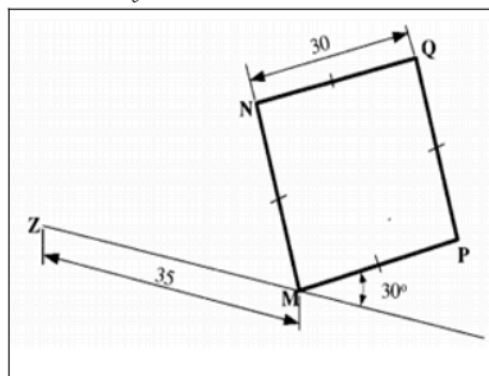
This question had two parts (a) and (b). Part (a) of the question was set from

the sub-topic of Scale. The students were required to prepare the marked scale bar in equal space using a scale of  $1\text{cm} = 1\text{m}$  indicating the point to be drilled. The question intended to assess the ability of the students to use scale in Engineering Drawing. The question was:

*Form two students were assigned to drill 13 holes on the 14m bar in equal space, but the last hole should be at 12.4m from the margin. Using a scale of  $1\text{cm}=1\text{m}$ , prepare the marked scale bar to indicate the point required to be drilled.*

In part (b), the students were required to enlarge the figure given into the ratio of  $5/3$  by using radial line method. The question intended to measure the ability of the students to use radial line methods in construction of similar figures. The question was:

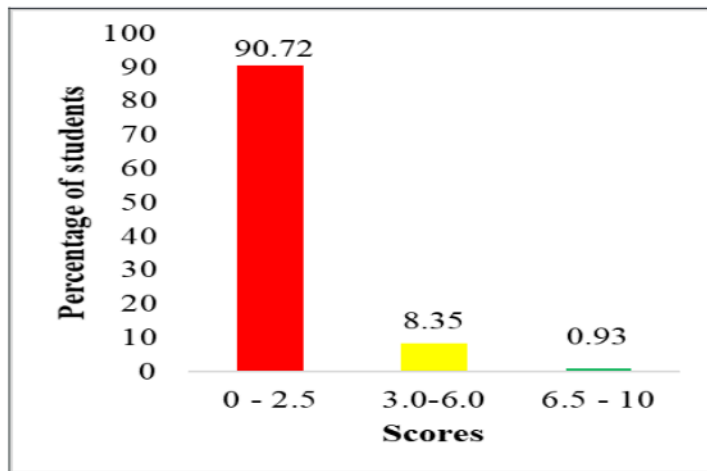
*The Figure below shows quadrilateral  $MPQN$  drawn in the angle of  $30^\circ$  with point  $M$ . By using radial lines method and point  $Z$  as the focal point; deduce the figure in the ratio of  $5/3$ .*



The question was attempted by 43 (100%) students. Figure 1 shows that, 391 (90.72%) students scored from 0 to 2.5 marks, 36 (8.35%) students scored from 3 to 6 marks and 4 (0.93%) scored from 6.5 to 10 marks.

This question was most poorly performed in this assessment paper. The students' performance is summarized in Figure 1.

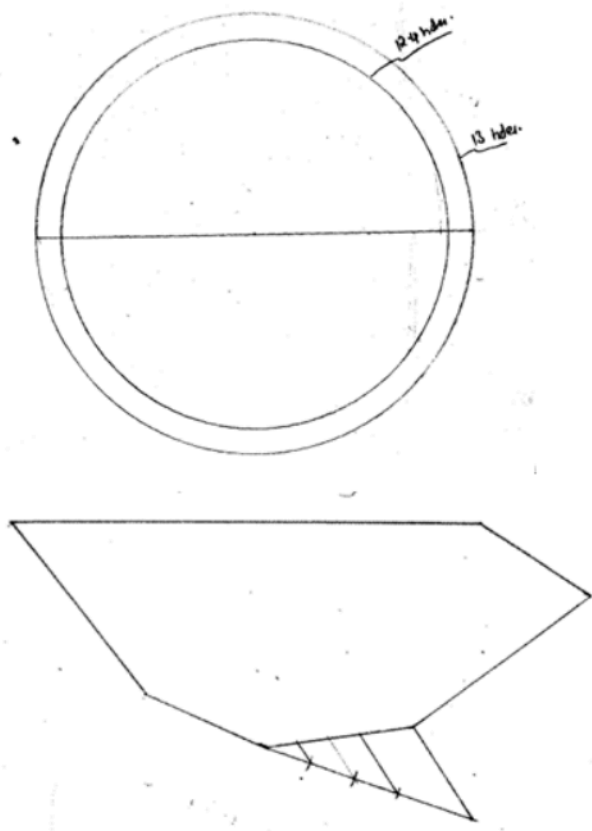




**Figure 1:** *Students' Performance in Question 1*

The students' inability to draw a bar in part (a) and the required equivalent figure in part (b) was the reason for their poor performance on this question. In item (a), the students lacked the knowledge to recognize that, the scale bar is a chart with a line divided into sections and is written or marked in length on the lower side by repetition of units, such as tens of kilometers or hundreds of miles. Therefore, the students failed to draw and prepare a scale bar marked with unity. As a result, the assessed students got a zero score in this part.

In part (b), the students could not develop a square drawing that should be drawn at  $30^\circ$  at point 'M' using the radial line method. Most of the students were only able to draw a line ZM with a length of 35 mm which was the first step in drawing this shape. Some students failed to draw a square directed at  $30^\circ$  from the line ZM. They also failed to extend line Z through M, N, O and P, and divide line ZM into five equal parts to use the ratio of 5 to 3 to draw the intended square. For example, one student could not follow the enlargement procedures. The given student was able to copy the question correctly, but s/he mistakenly enlarged the square drawing without using the ratio of 5/3. Extract 1.1 is an example of poor responses from a student who answered this question incorrectly.



**Extract 1.1:** A Sample of Students' Poor Response to Question 1

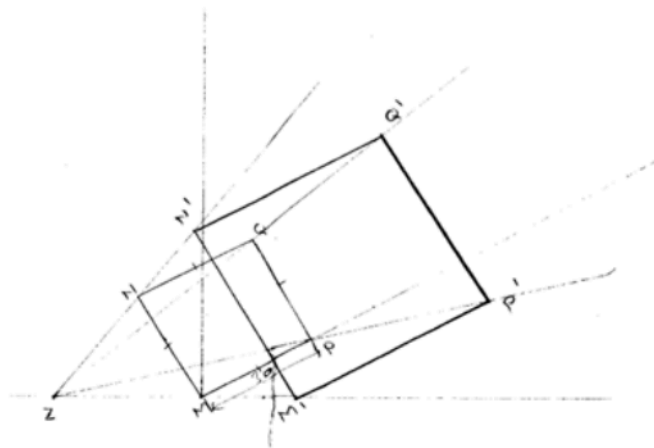
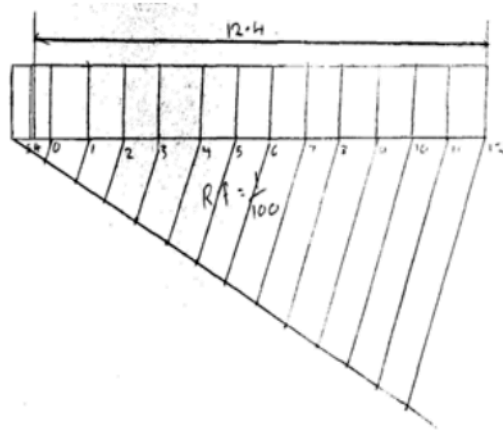
The response in Extract 1.1 shows the student who was not able to prepare a marked scale bar indicating the point required to be drilled. S/he drew a two concentric circles in part (a) and in part (b), s/he drew a drawing of an irregular figure. This indicates that, the student had inadequate knowledge especially on the sub-topic tested. S/he had low skill of drawing the given figure.

Furthermore, the responses of the 36 (8.35%) students with average performance reveal that, they had little knowledge and skills on the use of scale and similar figures. In part (a), some students managed only to remember that, the scale bar is a chart with a line divided into sections and length printed on the bottom by repeating units like tens of kilometres or hundreds of miles, but they failed to apply drawing skills for preparing a scale bar used to locate the point. Others drew correct scale bar in part (a) but failed to attempt part (b) thus ending up with average score in this question. Likewise, some students did well in part (b) but failed in part (a). They could draw the line ZM, a square angled at 30 degrees, and, a radial line from Z

through M, N, O, and P. Therefore, they obtained the enlarged square hence scored average marks.

Despite the mass failure in this question, there were few students 4 (0.93%) who in part (a) and (b) were able to attempt large parts of the question and therefore they scored above average. For example, most of the students in this group were able to calculate RF, calculate length of scale 14 cm, draw straight line of the required length and divide the straight line into a number of equal parts as required in in part (a). They were also able to subdivide the division, number and shows the distance on the scale bar. In this question, most of these students did not finish their work correctly as a result no student scored full marks which is 10.

Moreover, the students managed to draw line ZM, a square inclined at  $30^\circ$  and drew radial line from Z though M, N, O and P in part (b). In addition, these students showed the ability to divide the line ZM into three equal parts. The given students managed to score marks as they were able to extend the line ZM to get more equal parts; present thick visible outlines and ensure neatness in their drawings. Extract 1.2 is a sample of good responses from the scripts of one of the students.

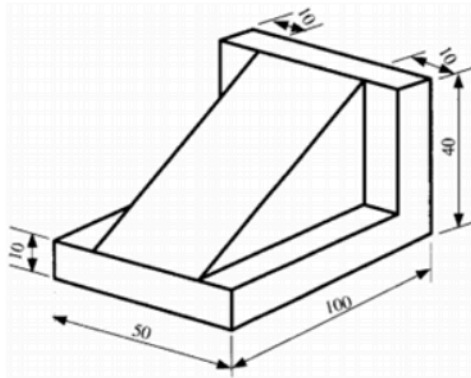


**Extract 1.2:** A sample of students' good response to Question 1  
 The response in Extract 1.2 shows that, the student applied the skills of scale conversion and enlarged the similar figure by following all procedures and steps to obtain the enlarged square.

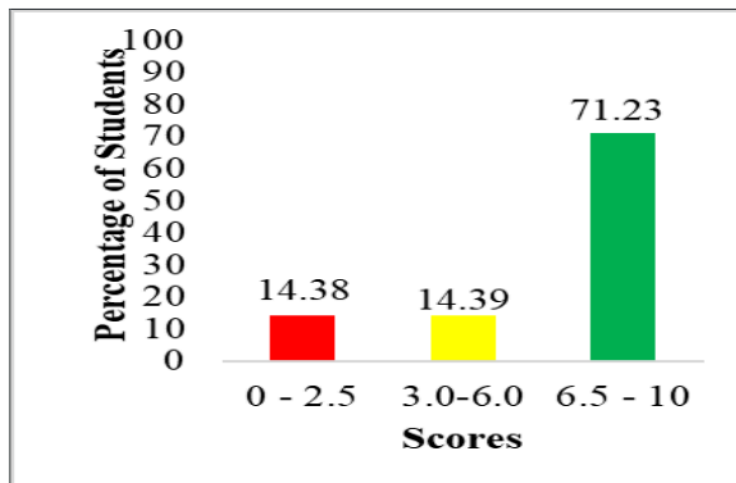
### 2.2.2 Question 2: Free Hand Sketching

The question required students to construct the free hand sketch of isometric projection with full size scale. The question intended to assess the ability of the students to apply free hand sketching technique in drawing isometric projection in Engineering Drawing. The question was as follows:

*The Figure below shows a hard plastic engine mounting require by a Car Company. By using full size scale and isometric projection; construct a free hand sketch of a part.*



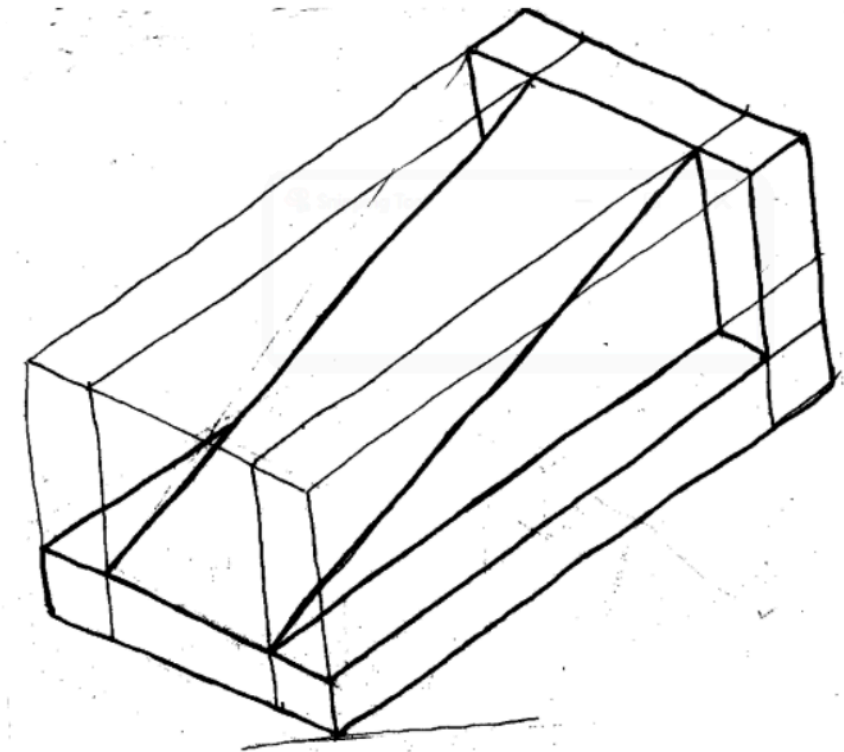
The question was attempted by 431(100%) students. The results in Figure 2 shows that, 62 (14.38%) students scored from 0 to 2.5 marks, 62 (14.39%) students scored from 3 to 6 marks and 307 (71.23%) scored from 6.5 to 10 marks. The majority of students 369 (85.61%) scored above average. This implies that, the performance of students in this question was good.



**Figure 2:** *Students' Performance in Question 2*

The 307 (71.23%) of students who had good performance had adequate knowledge of how to develop a free hand sketching in isometric projection. Most of these students had skills on free hand sketching technique since they managed to indicate construction lines, outlines and angle of orientation  $30^\circ$  as the first stage of drawing isometric projection. They managed to estimate and employed full scale as per question prescription. They also showed neatness during projection of the isometric drawing. Furthermore, these students managed to employ the most important rule in freehand sketching which is to keep the sketch in proportion. These students were able to accurately represent the size and position of each part in relation to the whole drawing. Extract 2.1 is a sample of good response from the script of one of

the students who attempted this question.



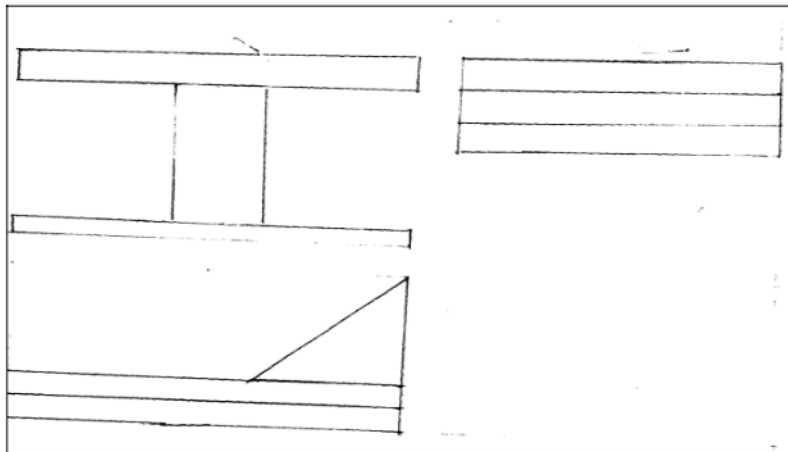
**Extract 2.1:** A sample of student's good responses to Question 2

Extract 2.1 shows the work presented by one of the students who attempted the question correctly. S/he managed to estimate, employ full scale and draw construction lines, angle of orientation  $30^\circ$  and outlines to display the required plastic engine mounting.

Further analysis shows that, 62 (14.39%) of the students with average performance partially attempted the question and scored average marks. The students in this group managed to draw the figure by using free hand sketching but they had a partial skill to construct a full-sized isometric projection. Some students were able to show construction lines but failed to represent angle of orientation. In fact, students from this group failed to show neatness of the sketch, correctness of figure and overlooked the dimensions. Other students sketched poor parallel sides as a result they constructed and obtained partially correct diagram from the required one.

Further analysis shows that, 62 (14.39%) of students had weak performance. These students had inadequate knowledge and skills about the sub-topic Free Hand Sketch and Isometric Projection. They did not manage to sketch

overall dimensions correctly and display isometric box which in turn could lead them to sketch the required isometric to a full size scale. Moreover, the students from this group were not able to show construction lines, outlines and angle of orientation. Further analysis reveals that, there were some students who confused between the sub-topic of Isometric and Orthographic Projection. Instead of sketching a hard plastic engine mounting in isometric projection, they drew wrong orthographic views of this plastic engine mounting. This reveals that, these students had inadequate knowledge about Isometric and Orthographic Projections and how they are related. In this regard, the free hand sketching was not known to some of the students. Extract 2.2 is an example of poor responses from a student whose answer was incorrect.



**Extract 2.2:** A sample of students' poor response to Question 2

Extract 2.2 indicates the misconceptions presented by one of the students who attempted the question poorly. S/he used the Orthographic Projection instead of using free hand sketching skills to draw the isometric projection.

### 2.2.3 Question 3: Construction of Geometric Figures

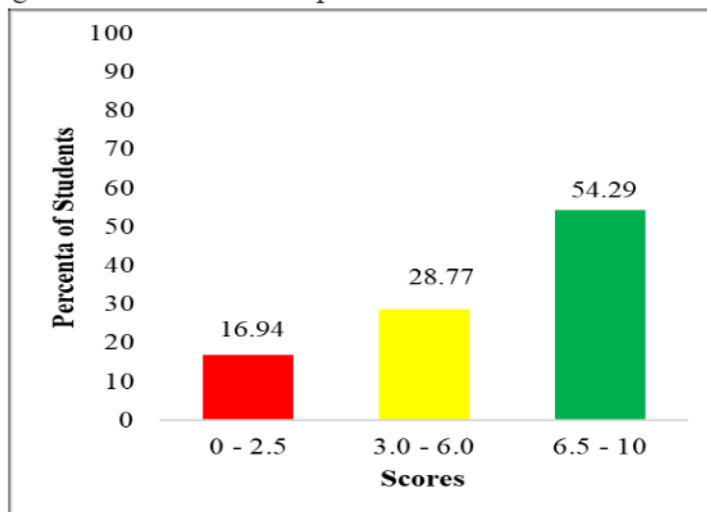
This question consists of two parts: (a) and (b). Part (a) required the students to construct the angle of  $30^\circ$  and  $45^\circ$  by using a ruler and compass. The question intended to assess the skills of students in constructing angles using drawing office tools like rulers and compass. The question was:

*With the help of a ruler and compass; construct the following angle: (i)  $30^\circ$   
(ii)  $45^\circ$*

In part (b), the students were asked to draw the circle with a diameter of 80 mm and show the parts of the circle. The question intended to assess the ability of the students to construct different geometrical figures in engineering drawing. The question was:

Draw a circle with diameter of 80 mm and show the following parts:  
(i) Tangent (ii) Normal (iii) Chord (iv) Arc (v) Sector  
(vi) Segment (vii) Radius (viii) Diameter (ix) Quadrant

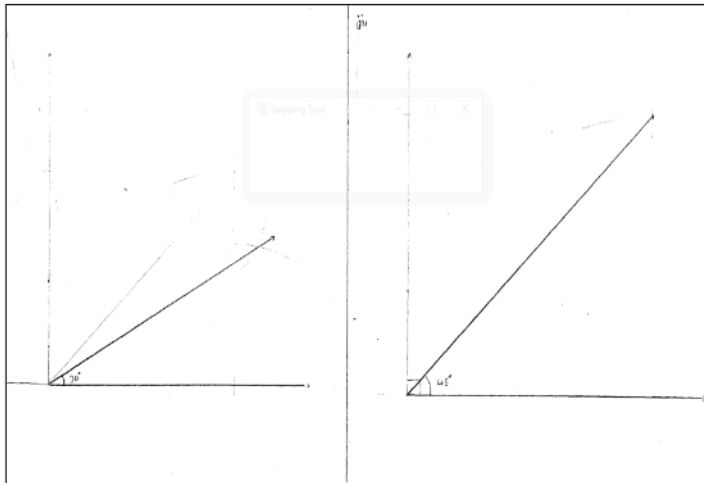
Among 431 (100%) students who attempted this question, 73 (16.4%) students scored from 0 to 2.5 marks, 124 (28.77%) students scored from 3.0 to 6.0 marks and the majority of students 234 (54.29%) scored from 6.5 to 10 marks. Figure 3 summarizes this performance.



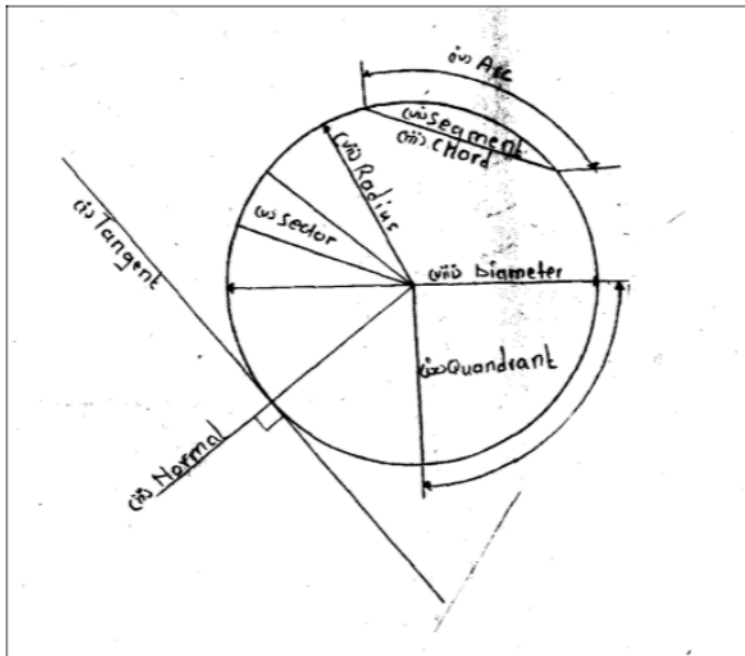
**Figure 3:** Students' Performance in Question 3

In this question, students were required to apply the knowledge of constructing geometric figures. The analysis shows that, 234 (54.29%) of students scored good marks in this question. The given students remembered the procedure of constructing angles by constructing lines, producing arc and managed to draw thick outlines in part (a). Moreover, the students drew circle of diameter 80 mm and showed all its parts in part (b). The students were familiar with construction of geometric figures. They managed to respond correctly to both part (a) and (b). In part (a), the students were able to draw a complete sketch of  $30^\circ$  and  $45^\circ$  angles and indicate the construction lines, outlines and arcs. In part (b), most of the students managed to use knowledge and skills on construction of geometric figures by drawing a complete circle with 80 mm diameter and managed to label all parts of the circle asked. This convinces that, these students had enough knowledge and practical skills on this sub-topic. Extract 3.1 is a sample of good response from one of the students who attempted this question.





**Extract 3.1 (a)** A sample of student's good response to Question 3 (a)



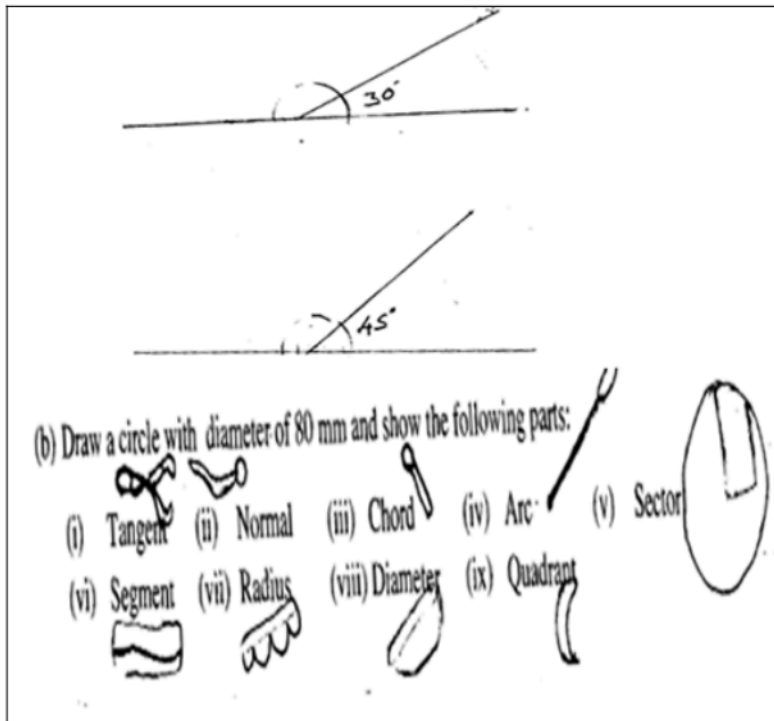
**Extract 3.1 (b):** A sample of student's good response to Question 3 (b)

Extract 3.1 (a) and (b) is the work of a student who drew angles correctly using rule and compass in part (a). S/he also had good performance in part (b) by drawing a circle and showing all its parts.

More analysis done on this question indicates that, 124 (28.77%) of the students had average performance as they partially attempted the question with respect to question requirements. Some of these students managed to

attend part (a) correctly by constructing a complete sketch with construction lines, outlines and arc but failed to attempt part (b). Others were able to respond correctly part (b) by drawing the circle of 80 mm diameter indicating the parts of the circle. However, they were not able to respond part (a) with correct sketch. Besides, some of the students being able to draw the circle correctly but they failed to indicate all parts of the circle as per question prescription in part (a). From this analysis, it is noted that the students in this group had partial knowledge and skills on the construction of geometric figures.

Further analysis reveals that, 73 (16.94%) of students scored below average. The given students lacked knowledge and skills of constructing geometric figures and angles by using compass and ruler in part (a). They drew irrelevant angles by failing to follow construction procedures. Others managed to obtain correct angle but used wrong procedures hence they scored zero in this part. For example, some students used wrong procedure of protractor to construct the  $30^\circ$  and  $45^\circ$  although they got correct angles. In part (b), most of these students were unable to draw a circle and show parts of the circle as required in the question. This indicates that, these students had inadequate knowledge in constructing and indicating the parts of the circle. Most of them drew a complete circle with 80 mm in diameter but failed to indicate any part. Extract 3.2 is a sample of poor response from one of the students.



**Extract 3.2:** A sample of student's poor response to Question 3

Extract 3.2 shows the response of the student who drew angles using protractor instead of compass and ruler to make angle of  $30^\circ$  and  $45^\circ$  in part (a). S/he provided the undefined sketch referring to the parts of the circle in part (b).

#### 2.2.4 Question 4: Symbol, Abbreviation and Dimensioning

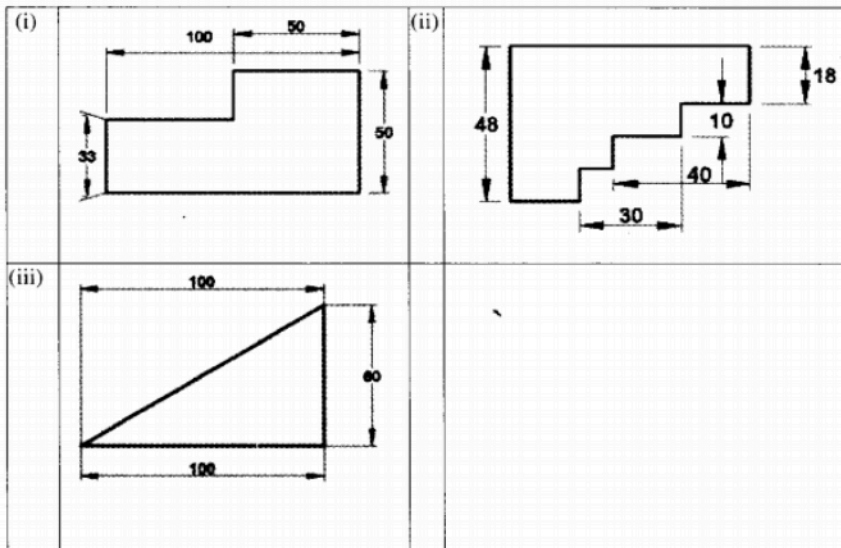
This question had two parts (a) and (b). In part (a), the students were required to illustrate the symbol of the welding techniques. The question intended to assess the ability of the students in using different welding technique symbols of welding process. The question was:

*A motor vehicle chassis was required to be welded with various welding technique at a Metal Welding Company. Illustrate how you would do the following welding techniques:*

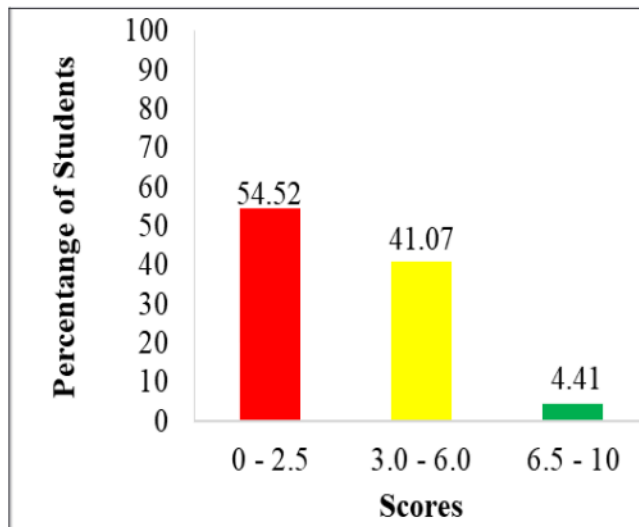
*(i) Fillet weld (ii) V butt weld (iii) Butt weld (iv) Spot weld.*

In part (b), the students were required to redraw the figures with correct methods of dimensioning. The question intended to assess students' knowledge and skills of dimensioning styles. The question was:

*Figures (i) – (iii) show mechanical parts drawn with incorrect rules of dimensioning. Re-draw the figures with the correct methods of dimensioning in the standard paper provided.*

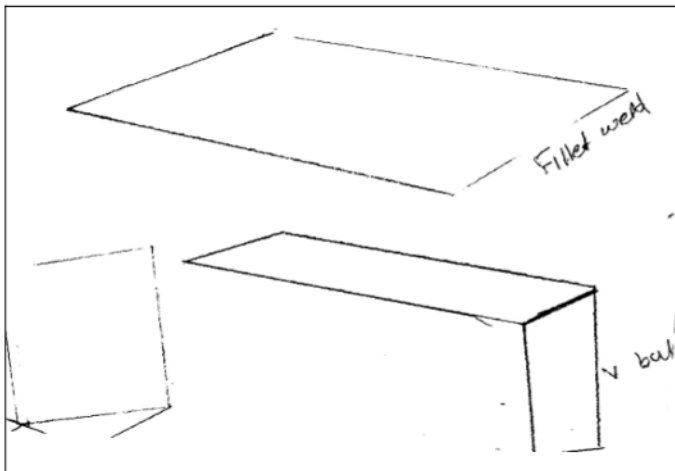


Among the 431 (100%) students who attempted the question, 235 (54.52%) scored from 0 to 2.5 marks; 77 (41.7%) scored from 3.0 to 6.0 marks and 19 (4.41%) scored from 6.5 to 10 marks. This analysis shows that, majority 196 (45.48%) of the students scored from 3 to 10 marks. The general performance of the students in this question was average. Figure 4 summarizes students' performance in this question.

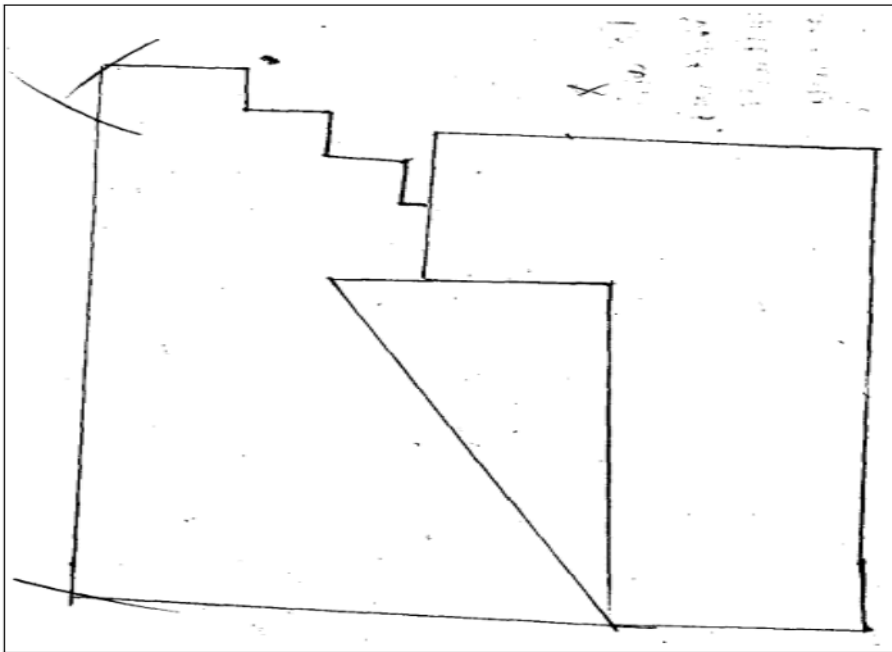


**Figure 4:** *Students' Performance in Question 4*

The analysis carried out on the students' responses in this question shows that, 235 (54.52%) of the students scored below average. Most of these students were unable to respond correctly in both parts. In part (a), the students failed to illustrate the welding techniques as per instruction due to lack of knowledge on symbols and abbreviation. In Part (b), the students had inadequate knowledge and skill on how to dimension an object. Some of them only copied the diagrams in the question without any correct response. They just redrew the figures provided but mismatched the correct method of dimensioning. Others from this group failed completely to redraw and indicate correct methods of dimensioning. The responses provided by these students show that, they were not conversant with the skills of dimensioning in this part (b). Further analysis on this group exposes that, these students had inadequate knowledge and skills on the sub-topic of symbol, abbreviation and dimensioning. Extract 4.1 is a sample of poor response taken from the script of one of the students.



**Extract 4.1 (a):** A sample of student's poor response to Question 4



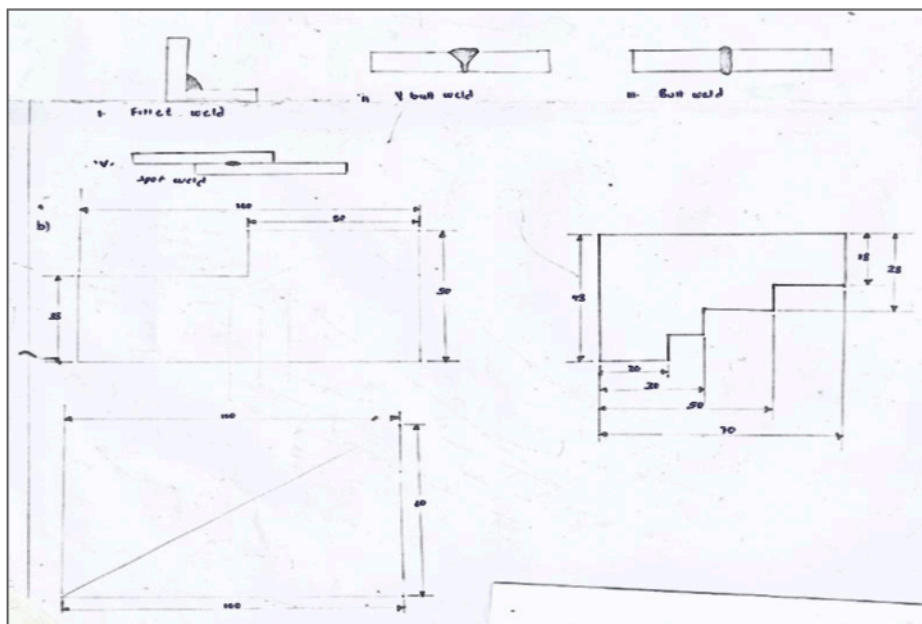
**Extract 4.1(b):** A sample of student's poor response to Question 4

Extract 4.1(a) shows the response of the student who incorrectly illustrated welding technique during metal joining in part (a). S/he drew the undefined sketch as well as failed to redraw the given figure with a correct method of dimension in part (b).

Furthermore, 177 (41.07%) students had average performance as they had limited knowledge with regard to symbols, abbreviation and dimensioning in engineering drawing. It is further reveals that, some of these students were able to illustrate some welding techniques by giving correct symbol but

mismatched the naming of symbols of welding techniques. In part (b), the students provided partial responses, as they were able to redraw the figures correctly but lacked correct arrangement of dimension lines. Some students in this group were able to respond correctly part (a) but failed in part (b) and the vice versa.

Despite of low and average scores, 19 (4.41%) students performed well in this question. Their responses proved that, the students were familiar with sub-topics of Symbols, Abbreviation and Dimensioning. Most of them provided relevant response in part (a) and (b). They illustrated correctly welding technique symbols demanded in the question. For example, one student drew the welding symbols for fillet weld, v-butt weld, butt weld and sport weld in part (a). S/he managed to draw and dimension the diagram with correct methods of dimensioning in Part (b). Most of the students employed knowledge and skills acquired to draw and name welding joint and proper dimensioning techniques to align the measurement as demanded in the question. Extract 4.2 is a sample of good response provided by one of the students.



**Extract 4.2:** A sample of student's good response to Question 4

Extract 4.2 shows the response of the student who attempted correctly by drawing the welding technique of metal joining in part (a). S/he redrew the figure provided. S/he also used the correct method to dimension the figures.

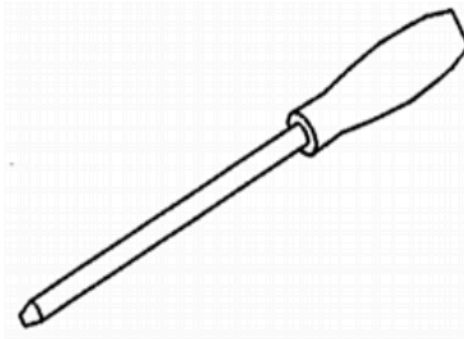
## 2.2 Section B: Short Answer Questions

Section B had three (3) questions. The questions were set from the topics of *Engineering drawing I and Engineering drawing II*. Students were instructed to answer all the questions. Section B had 60 marks, with 20 marks assigned to each question.

### 2.2.1 Question 5: Free Hand Sketching and Pictorial drawing

This question had two parts, (a) and (b) from the sub-topic *Free Hand Sketching*. In part (a), the students were required to sketch a mechanical tool in isometric projection by employing free hand method. This part intended to assess the students' ability to link and use the knowledge and skills acquired in both free hand sketching and isometric projection in drawing a mechanical tool. The question was:

- (a) *Using free hand method and isometric projection, construct the mechanical tool shown in the figure.*



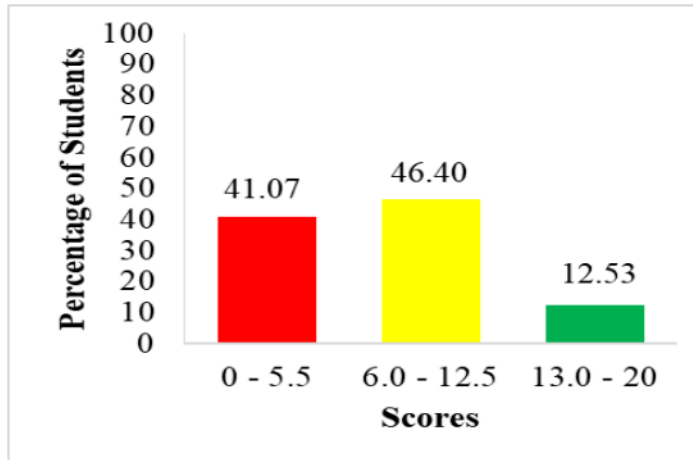
In part (b), the students were required to design a square pyramid in oblique projection to be used for football coaching activities. This part intended to assess the students' ability to use pictorial drawing knowledge in designing the square pyramids in oblique projection. The question was:

*A football coach needs several squares plastics pyramids to be used in his coaching activities. Design a required squared pyramids to be manufactured in oblique projection. The altitude of pyramids is 80mm and its sides is 40mm.*

The question was attempted by 431 (100%) students from which 177 (41.7%) students scored from 0 to 5.5 marks; 200 (46.40%) students scored from 6.0 to 12.5 marks and 54 (12.53%) scored from 13 to 20 marks.

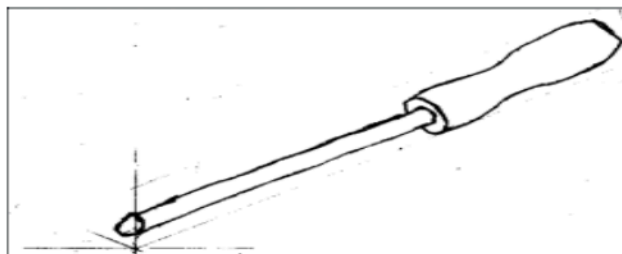


The general performance of this question summarized in Figure 5.

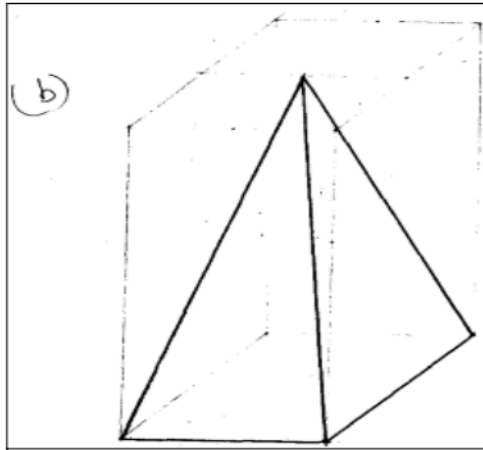


**Figure 5:** *Students' Performance in Question 5*

On the other hand, some students 54 (12.53%) scored good marks. They constructed a clear sketch in either both parts or large area of the two parties (a) and (b). Some of these students gave correct responses by drawing a mechanical tool without using drawing tools in part (a). They were also able to draw a pyramid by following the procedure for oblique projection in part (b). In this part, the students knew that one side of an oblique box is drawn at  $45^\circ$ . In that case, they were able to draw a box with one side at  $45^\circ$ . They constructed the pyramid with its apex at 80 mm high. Furthermore, they designed a required squire pyramid by indicating all necessary parts as construction lines, correct angle and their sketches were visible, correct and neat. The students in this group had good skills and practices in both free hand sketching and pictorial drawings. Extract 5.1 (a) and (b) are the sample responses from a student who had good performance.



**Extract 5.1 (a):** A sample of student's good response to Question 5(a)



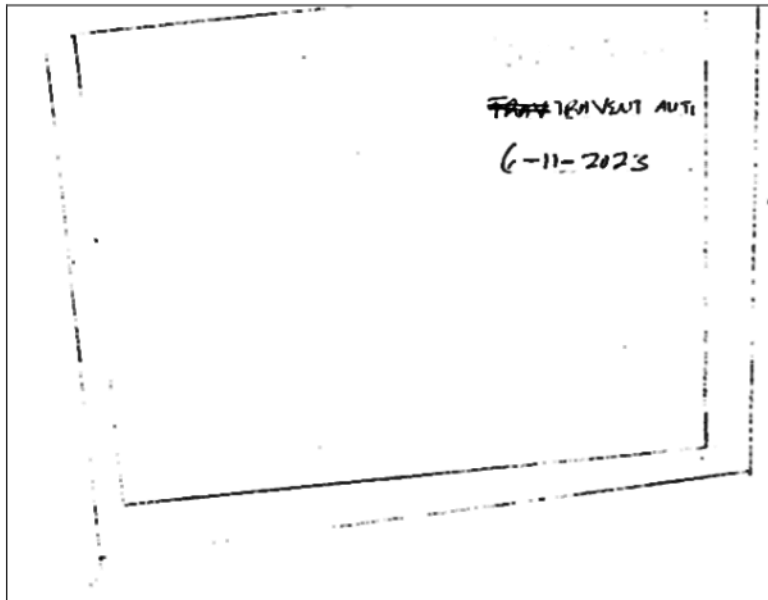
**Extract 5.1 (b):** A sample of student's good response to Question 5(b)

The response in Extract 5.1 shows a student who had good understanding in both parts. S/he redraw by free hand the mechanical tool and a square pyramid in (a) and (b) respectively.

Further analysis shows that, 200 (46.40%) students had an average score. These students were able to answer one part and failed to answer the other part correctly or partially answered all parts (a) and (b). For example, one student was able to draw a mechanical tool in part (a). S/he drew a mechanical tool in isometric projection employing a freehand sketching knowledge, but the same student failed to draw a square plastic pyramid in oblique projection in part (b). Others were able to answer both parts (a) and (b) correctly but all the lines were faint. There was no difference between visible lines and construction lines, thus leading to lower scores and getting average scores.

The analysis further depicts that, 177 (41.07%) of the students scored below the average. Most of them from this group were not able to draw by free hand hence they employed tools to draw in part (a). In part (b), they failed to even draw a box in oblique projection which would lead to draw a square plastic pyramid. Their responses reveal that, they lacked skills to sketch different diagrams by free hand sketching in part (a) and lacked knowledge on oblique projection. Based on their responses, there were those who were able to draw in part (a) using tools instead of free hand sketching and in part (b) they drew a square plastic pyramid in isometric projection instead of oblique projection, thus ended up getting weak scores in this question. These students did not know that, the box employed to draw an object in oblique

projection has one side at an angle of  $45^\circ$  whereas in isometric projection both sides of the box are at an angle of  $30^\circ$ . Apart from mistakes of putting incorrect dimensions in drawing part (b), most students in this group did not have the skills to find the apex of the pyramid hence drew the wrong pyramid. Some of these students drew their sketches with incorrect dimensions and unsatisfactory neatness. Extract 5.2 is a sample response from a student who had poor performance.



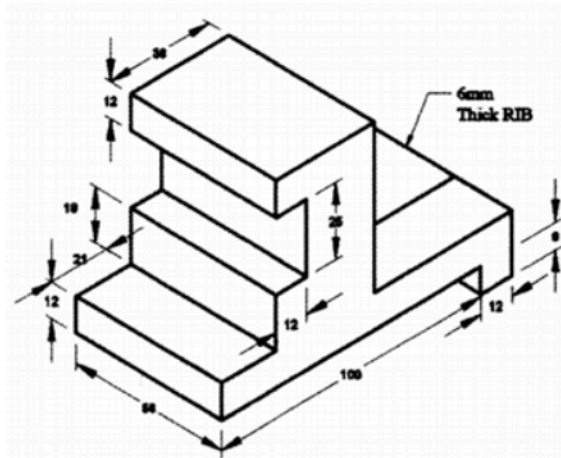
**Extract 5.2:** A sample of student's poor response to Question 5

The response in Extract 5.2 shows the incorrect diagram drawn by one of the student. The student provided substandard title block and failed to use free hand sketch skill to draw a mechanical tool in part (a).

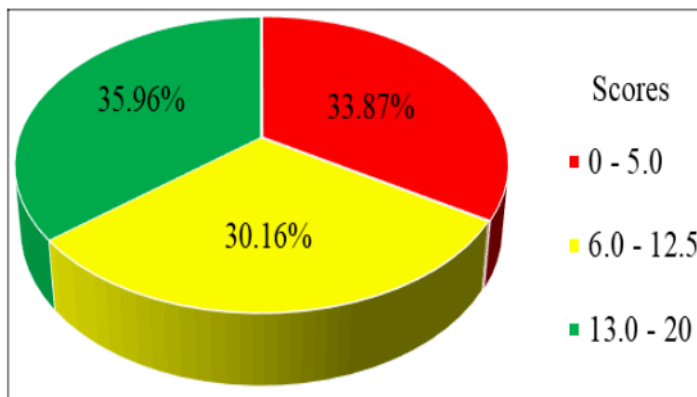
### 2.2.2 Question 6: Pictorial Drawing

This question was selected from sub-topic of Pictorial Drawing. The students were required to draw a full-size scale of the isometric projection. The question intended to measure ability of students to draw isometric projection in full scale size. The question was:

*The Figure below is a pictorial view of casted block; draw in full scale size the isometric projection of a block. All construction lines should be clearly shown.*



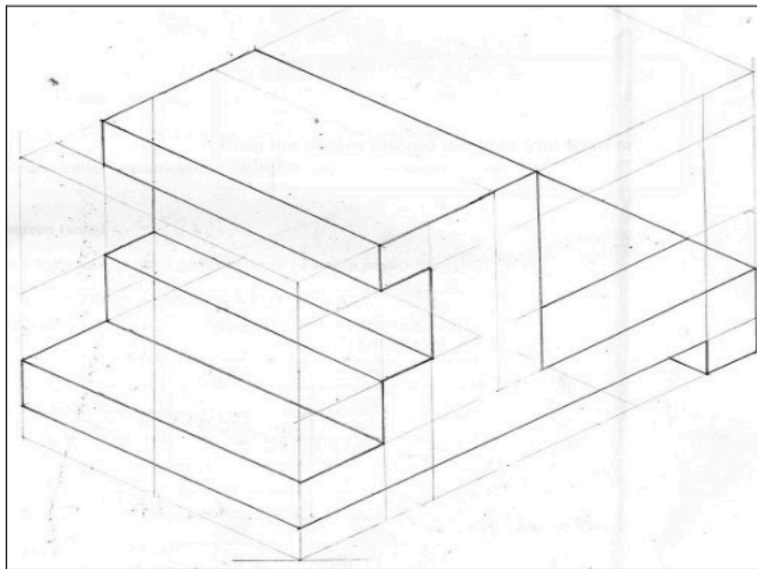
The question was attempted by 431 (100%) students whereby 146 (33.87%) scored from 0 to 5.5 marks, 130 (30.16%) students scored from 6 to 12.5 marks and 155 (35.96%) students scored from 13 to 20 marks. Generally, the performance in this question was good as the majority of the students 285 (66.13%) scored average and above. Figure 6 summarizes the performance of the students in this question.



**Figure 6:** *Students' Performance in Question 6*

This is among the questions which was done well since 285 (66.13%) students scored average and above. From this group, 155 (35.96%) students scored between 13 and 20 with regard to the question's requirements. Their responses indicate that, they had enough knowledge and skill of constructing the isometric object hence they managed to follow correctly the procedures. They were able to construct isometric principal two lines in  $30^\circ$  with which they defined the three sides of an isometric box. Furthermore, they managed to draw construction lines to produce an isometric box, thus plotting the pictorial view in the isometric box as well as producing thick visible outlines for an isometric.

This analysis implies that, the students who scored full marks in this group understood the requirement of the question and had sufficient skills on this sub-topic of *Isometric projection*. Others from this group were able to draw all the steps of the isometric projection of the block but they could not draw thick some visible lines related to the isometric block, thus getting higher but less than 20 marks allotted to this question. Further analysis of these students who got high marks shows that the marks varies between 13 and 20 due to either missing visible lines, some dimensions being incorrect or some construction lines or visible isometric block lines being not drawn. Extract 6.1 is a sample response from a student who had good performance.

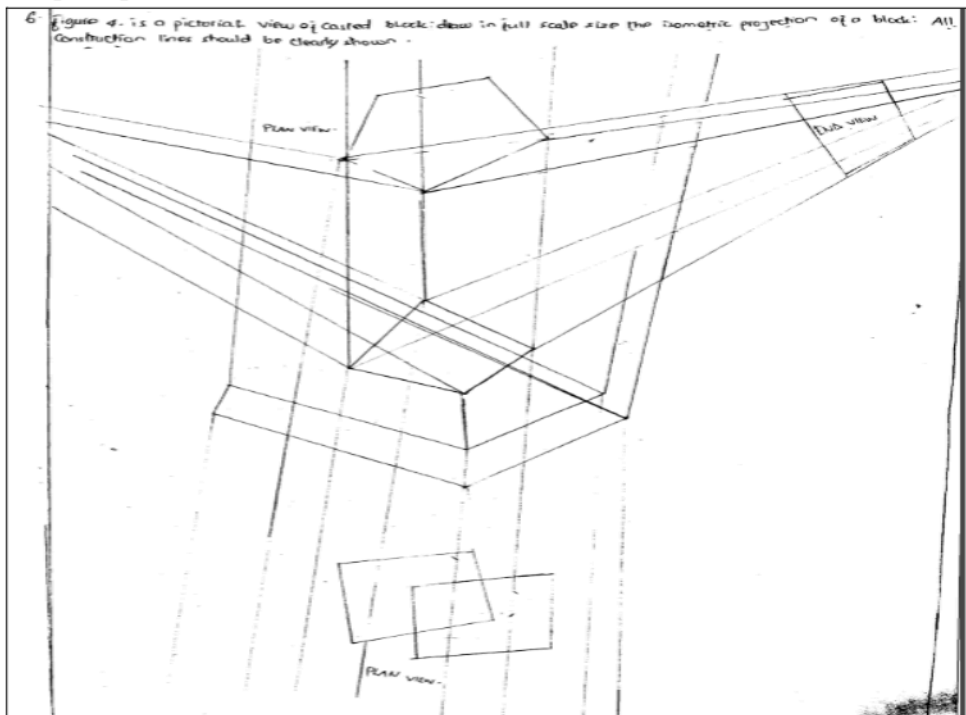


**Extract 6.1** A sample of a student's good response to Question 6.

Extract 6.1 shows the correct work done by the student who correctly reproduced an isometric object as required. The student followed all the procedure by drawing an isometric box of the base line at  $30^\circ$  angle and then projected different construction lines to obtain the isometric object.

Despite of the students who scored higher scores, 130 (30.16%) of the students had average score of 6 to 12 marks. These students understood the requirements of the question and responded correctly by following some of the procedures, but they made few mistakes that hindered them from scoring outstanding higher marks. Some of the mistakes made include failure to indicate isometric box, construction lines and alignment of the figure in isometric box. Also, some of them were unable to show isometric orientation, overall dimensions, thick visibility and neatness of the drawing.

On the other hand, 146 (33.88%) of the students scored from 0 to 5 marks. These students either did not understand the demand of the question or lacked the knowledge on the sub-topic, Pictorial Drawing as well as drawing skills to redraw the casted block. Some of these students drew correctly an isometric box with some construction line but were unable to plot the figure in the isometric box thus ending scoring low marks. Some students did not use a full scale as it could be depicted in the question. They used wrong dimension as they did not produce an isometric box as a result they ended up with only unclear construction lines. There were also students who could not differentiate between isometric projections with other projections. Instead of drawing an isometric box as a starting point, they drew either oblique or perspective projection with wrong construction line. Most of the students did not achieve to complete some information on their sketch such as isometric box, construction lines and plotting the figure in isometric box. Mostly, their sketches lacked visible outlines, overall dimension, isometric orientation and neatness. This analysis indicates that, most of the students did not understand the demand of the question. About 63 (14.62%) students ended up scoring zero mark. Extract 6.2 is a sample response from a student who had poor performance.



**Extract 6.2:** A sample of student's poor response to Question 6

The response in Extract 6.2 shows the incorrect work done by the student

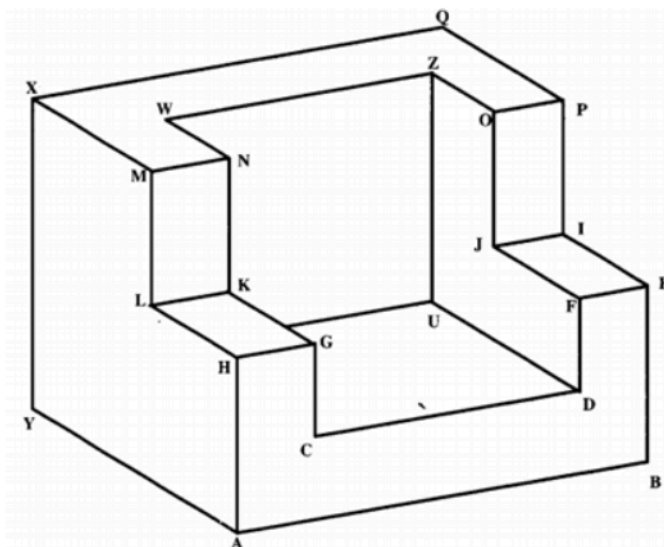
who did not understand the requirement of the question. Instead he/she drew undefined figure. This student was not knowledgeable on all the competences tested in this question.

### 2.2.3 Question 7: Pictorial Drawing and Dimensioning

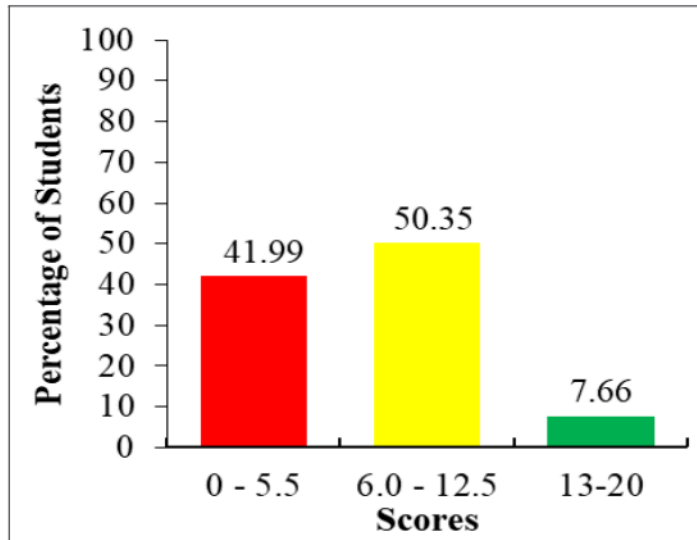
This question was derived from the sub-topic of *Pictorial Drawing and Dimensioning*. Students were required to draw stopper in full size and dimensioning by using principles and rules of dimensioning process. The question intended to assess the ability of the students to use the principles and rules of dimensioning, and redraw an isometric projection in full scale size. The question was:

*The Figure below shows the stopper drawn in isometric projection. Draw the stopper in full size dimensions using principles and rules of dimensioning. The dimensions of the object are as follows:*

- (a)  $AB=XQ=60\text{ mm}$
- (b)  $XY=50\text{ mm}$
- (c)  $CD=WZ=40\text{ mm}$
- (d)  $UZ=40\text{ mm}$
- (e)  $YA=40\text{ mm}$
- (f)  $AH=BE=30\text{ mm}$
- (g)  $ML=NK=OJ=PI=20\text{ mm}$
- (h)  $IE=JF=KG=LH=20\text{ mm}$
- (i)  $OZ=NW=10\text{ mm}$
- (j)  $OP=NM=10\text{ mm}$



The question was attempted by 431(100%) students in which 181 (41.99%) students scored from 0 to 5.5 marks, 217 (50.35%) students scored from 6 to 12.5 marks and 33 (7.66%) scored from 13 to 18.5 marks. Figure 7 summarizes this performance.



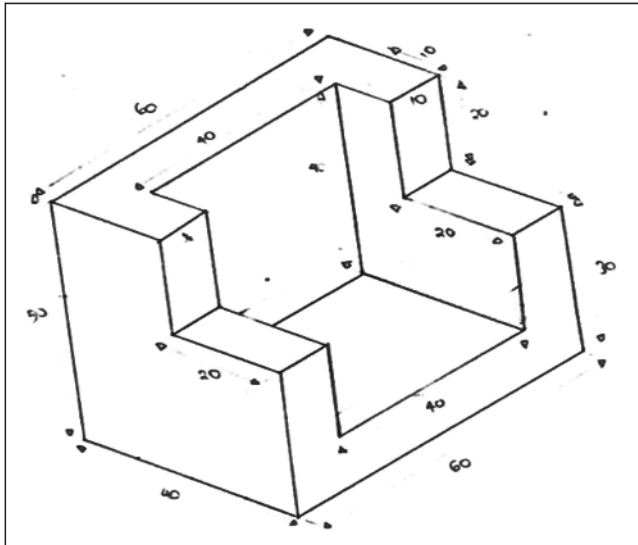
**Figure 7:** *Students' Performance in Question 7*

This question had average performance as 250 (58.00%) students scored average marks and above. Some of them answered the question accurately with a few errors thus, scoring from 6 and less than 20 marks. For the students who scored higher scores (13 to 18.5 marks), followed procedure of drawing processes and showed isometric drawing information such as construction of isometric box. They also redrew the figure, dimensions and correct overall dimensions, extension line offset from object, written dimension number without units, no repetition of dimensions and the neatness of drawn isometric view.

Other students in this group made some mistakes in the procedure by not drawing some visible lines or construction lines. Others made a mistake in writing some dimension numbers, or drew some incorrect extension lines.

Regardless of such observed mistakes, many students in this group did well. They were knowledgeable and skilled on the dimensioning processes hence attempted the question correctly. Extract 7.1 is a sample of good response provided by a student with good performance.





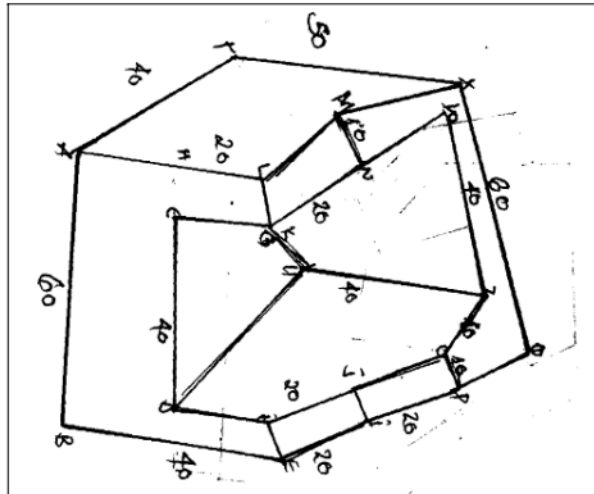
**Extract 7.1:** A sample of a student's good response to Question 7

Extract 7.1 shows the correct response provided by a student who drew the stopper in full size dimension and applied the principles and rules of dimensioning. S/he drew the stopper in an isometric and dimensioned as required by the question.

The analysis done on the students' responses in this question reveal that, 217 (50.35%) of the students had average scores. These students with average performance only partially answered the question. They had little knowledge and skills of drawing the stopper in full size dimension using principle and rule of dimensioning. Some of them had ability to allocate partial isometric drawing informations like isometric box, redraw the figure given, and correct overall dimensions and extension line offset from object. Nevertheless, the students were not able to show neatness, dimension text without units and parallel lines as a result they ended up scoring average scores.

Despite of the good and average performance in this question, 181 (42.00%) had weak performance. These students lacked knowledge and skills of constructing by copying the pictorial drawings in isometric projection. Most of them provided irrelevant response due to the inability and lack of drawing techniques of sketching and constructing isometric views. The majority of the students in this group failed even to copy the give pictorial drawing. They were also unable to find an opportunity to dimension the diagram because they could not draw the intended drawing. Nevertheless,

103 (23.90%) students in this group scored zero marks. Extract 7.2 is a sample response from a student who had poor performance.



**Extract 7.2:** A sample of a student's poor response to Question 7

Extract 7.2 shows an incorrect response provided by a student who could not copy the correct drawing. S/he failed also to assign any dimension correctly.

### 3.0 ANALYSIS OF STUDENTS' PERFORMANCE IN EACH TOPIC

The assessment paper of Engineering Drawing comprised of seven questions from various topics of Form I and II. The analysis on the students' performance indicates that, questions 3 from the topic of *Construction of Geometric Figures* and 2 and 5 from the sub-topic of *Free Hand Sketching* had good performance since the percentages of the students who passed were 83.06% and 72.27% respectively. The questions which were performed averagely were question 4, 6 and 7. These questions were set from the topics of *Pictorial Drawing* (62.07%) and *Dimensioning, Symbols and Abbreviation* (45.48%), respectively. The analysis further shows that, one question had weak performance as most of the students scored below 30 percent. This question was set from the topic of *Similar Figure and Scale* (9.28%). Appendix 1 summarizes the students' performance in each topic.

## **4.0 CONCLUSION AND RECOMMENDATIONS**

### **4.1 Conclusion**

Based on the students' responses analysis of each question, it can be concluded that the overall performance was good in Engineering Drawing subject on the FTNA of 2023. This is justified by the students' performance in which 73.55 percent of the students passed the Assessment.

The majority of the students had good performance in question 2, 3 and 6 from the sub-topics of *Free Hand Sketching*, *Construction of Geometric Figures* and *Pictorial Drawings*. Additionally, the students performed averagely in questions 4, 5 and 7. These questions were set from the sub-topics of *Dimensioning*, *Symbols and Abbreviation*, *Free Hand Sketching* and *Pictorial Drawings* respectively.

In contrast, the students' weak performance was observed in question 1 from the sub-topic of *Scale and Enlargement*. The reason of failure in this sub-topic is students' failure to follow drawing procedures, and inability to use drawing instruments properly. It is therefore expected that, this report will help students, teachers and other education stakeholders to address the weaknesses identified in the report to enhance good performance in upcoming assessments.

### **4.2 Recommendations**

To improve more in future, the following are therefore recommended:

#### **4.2.1 Recommendations to Students**

- (a) Students should practice more on how to:
  - (i) use each scale and enlargement. Practices would help them become competent in demonstrating the use of scales during drawing activity.
  - (ii) distinguish visible lines from construction lines whereas, construction lines are supposed to be faint during execution of different figures and drawings.
  - (iii) dimension accurately different types of figures and symbols.
- (b) Students should be guided and exposed to many practices on application of the rules and procedures in constructing enlargement of plane figures using the given ratios.

#### **4.2.2 Recommendations to Teachers**

- (a) Teachers should give students more activities either individual or group assignments on:
  - (i) scale applications. This will enable them to subdivide the equal portions.
  - (ii) redrawing and converting diagrams from isometric using free hand sketching techniques.
  - (iii) how to draw and enlarge figures by employing most preferable techniques. This will help students to become competent on figure enlargement.
- (b) Teachers should build the capacity of the students to draw different figures by hand without using drawing tools and instruments. This should be done by controlling the drawing process solely with their hands.

**Appendix I: A Summary of Students' Performance (Question-Wise) in Engineering Drawing, 2023**

S/N	Topic	Sub -Topic	Performance for Each Topic		Remarks
			Question Number	Percentage of Students who Scored 30% or More	
1.	Engineering Drawing I	Construction of Geometric Figures	3	83.06	Good
2.	Engineering Drawing I	Free Hand sketching	2 and 5	72.27	Good
3.	Engineering Drawing II	Pictorial Drawings	6 and 7	62.07	Average
4.	Engineering Drawing II	Dimensioning, Symbols and Abbreviation	4	45.48	Average
5.	Engineering Drawing I	Scale and Similar Figures	1	9.28	Weak

**Appendix II:** Students' performance Grade-wise in 2023 in Comparison  
2022

<b>Year</b>	<b>A</b>	<b>B</b>	<b>C</b>	<b>D</b>	<b>F</b>	<b>Total</b>
<b>2023</b>	12	50	142	113	114	<b>431</b>

