



**THE UNITED REPUBLIC OF TANZANIA  
MINISTRY OF EDUCATION, SCIENCE AND TECHNOLOGY  
NATIONAL EXAMINATIONS COUNCIL OF TANZANIA**



**STUDENTS' ITEM RESPONSE ANALYSIS REPORT  
ON THE FORM TWO NATIONAL ASSESSMENT  
(FTNA) 2021**

**ENGINEERING SCIENCE**



**THE UNITED REPUBLIC OF TANZANIA  
MINISTRY OF EDUCATION, SCIENCE AND TECHNOLOGY  
NATIONAL EXAMINATIONS COUNCIL OF TANZANIA**



**STUDENTS' ITEMS RESPONSE ANALYSIS REPORT  
ON THE FORM TWO NATIONAL ASSESSMENT  
(FTNA) 2021**

**035 ENGINEERING SCIENCE**

Published by  
National Examinations Council of Tanzania,  
P.O. Box 2624,  
Dar es salaam, Tanzania.

**© The National Examinations Council of Tanzania, 2022**

All rights reserved.

## Table of Contents

FOREWORD.....	iv
1.0 INTRODUCTION .....	1
2.0 ANALYSIS OF STUDENTS' RESPONSES TO EACH QUESTION .....	2
2.1 SECTION A: Objective Questions .....	2
2.1.1 Question 1: Multiple Choice Question .....	2
2.1.2 Question 2: Matching Items - Linear Motion .....	11
2.2 SECTION B: Short Answer Questions .....	14
2.2.1 Question 3: Linear Motion.....	14
2.2.2 Question 4: Electricity .....	18
2.2.3 Question 5: Friction .....	23
2.2.4 Question 6: Heat .....	27
2.2.5 Question 7: Measuring Instruments.....	31
2.2.6 Question 8: Simple Machines .....	34
2.2.7 Question 9: Work, Energy and Power .....	38
2.3 SECTION C: Structured Question .....	43
2.3.1 Question 10: Electricity.....	43
3.0 THE STUDENTS' PERFORMANCE IN EACH TOPIC .....	52
4.0 CONCLUSION AND RECOMMENDATION .....	52
4.1 Conclusion .....	52
4.2 Recommendation .....	53
Appendix I.....	54
Appendix II.....	55

## FOREWORD

The students' items responses analysis report on the 2021 Form two National Assessment (FTNA) Engineering Science subject was written to provide feedback to students, teachers, parents, policy makers and the public on the performance of the students and the challenges they encountered in attempting the questions.

The FTNA marks the end of two years of Ordinary level Secondary Education. It is a formative evaluation whose effectiveness shows the achievement of the education system in general and the education delivery system in particular. Basically, the students' responses to the assessed question is one of the indicators of what the educational system was able to provide during their first two years of ordinary level of secondary education.

The report highlights the factors that influenced the students' ability and inability to respond to the questions. The students were able to respond correctly to the assessed questions due to; ability to understand the task of the question and being knowledgeable on the concept tested. On the other hand, students' failure was influenced by inability to understand the task of the question, failure to use the formula to calculate the required parameters as a result they failed to undergo mathematical manipulation.

The feedback provided will help educational administrators, school managers, teachers, students and other stakeholders to identify proper measures to improve the FTNA students' performance in future.

The National Examinations Council of Tanzania is grateful to the all stakeholders who provided valuable assistance in the preparation of this report in various capacities.



Dr Charles E. Msonde  
**EXECUTIVE SECRETARY**

## 1.0 INTRODUCTION

This report analyses students' performance in the 2021 Form Two National Assessment (FTNA) in the Engineering Science subject. The Assessment focused on the students' competences as per the Form I and II Engineering Science Syllabus. The report shows students' performance question-wise by identifying the students' strengths and weaknesses per each questions attempted.

The Engineering Science paper had ten (10) questions which were divided into three (3) sections A, B, and C. Section A comprised of two (2) questions; Question 1 consisted of ten (10) multiple choice items, where each item carried 1 mark. Question 2 consisted of five (5) matching items, each item carried 1 mark. Section B consisted of seven (7) short answer questions, each carrying ten (10) marks. Section C consisted of one (1) structured question which carried fifteen (15) marks. The students were required to answer all questions in all sections. The analysis of each question has been done in which an overview of what students were required to do, the general performance and reasons for their performance is given. Extract of good and poor students' responses are included in the analysis.

The number of students who sat for FTNA 2021 in this subject was 1,673 of which 897 (53.62%) students passed and 776 (46.38%) students failed. In 2020, a total of 1,692 students sat for the assessments in which 808 (47.75%) passed while the remaining 884 (52.25%) students failed. This indicates that there is an increase of 5.87 percent of the students who passed examinations in 2021 compared to 2020.

The performance of students in this report is regarded as poor, average, and good if the percentage of students' performance range from 0 – 29, 30 – 64, and 65 to 100 respectively. This performance is presented in Figures and Tables using colours whereby red, yellow, and green colours are used for poor, average and good performance respectively. Figure 1 shows overall performance of 1,673 students who sat for the Engineering Science National Assessment in November 2021.

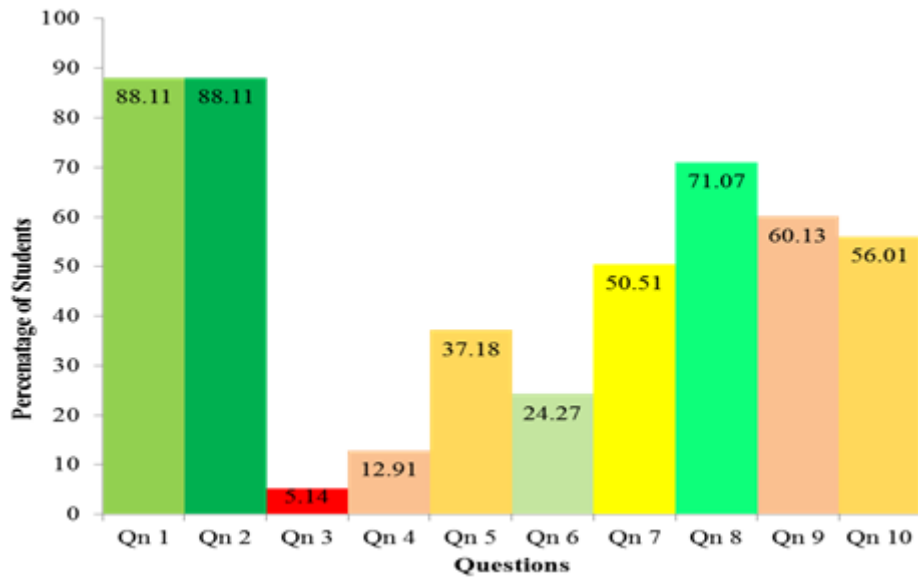

**Figure 1:** The general students' performance in Engineering Science for Individual question.

## 2.0 ANALYSIS OF STUDENTS' RESPONSES TO EACH QUESTION

### 2.1 SECTION A: Objective Questions

This section consisted of two objective questions. Question 1 weighed 10 marks, and Questions 2 weighed 5 marks. Each item of the question carried 1 mark. The section carried a total of 15 marks.

#### 2.1.1 Question 1: Multiple Choice Question

Question 1 consisted of ten multiple choice items, (i) to (x), which covered various concepts from the following topics: *Measurement, Simple Machine, Force, Friction, Heat, Sound, Electricity, Work, Energy and Power, and Turning Force*. A student was required to choose the correct answer from the given alternatives and write its letter against the item number.

This question was attempted by 1673 (100%) students. The statistics show that 11.89 percent of students scored from 0 to 2 marks, 64.49 percent scored from 3.0 to 6.0 marks and 23.61 percent scored from 7 to 10 marks. The performance of students in this question is illustrated in Figure 2.

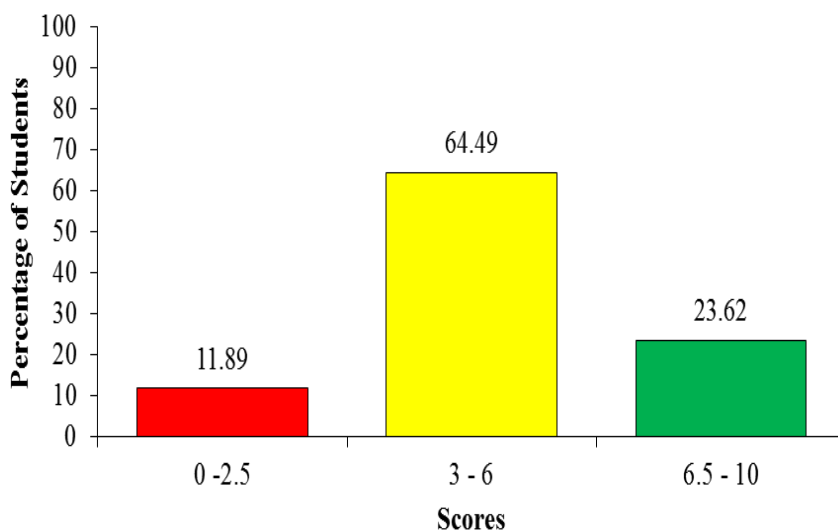

**Figure 2:** *Students' Performance in Question 1*

Data in Figure 2 shows that, most of the students (64.49%) scored 3 to 6 marks. These students provided the correct answers for 3 to 6 items. Moreover, 23.61 percent of the students were able to answer 6 to 10 items correctly. Out of these only 3 (0.2%) students scored 10 marks allocated to this question. These students were knowledgeable on the tested concepts which helped them to identify the correct response in all items.

Further analysis shows that, the item which most of the students selected the correct responses was item number (i). This item measured the concept on measurements. This suggest that the students acquired the appropriate knowledge necessary to identify and allocate the required measuring instrument. Items (ii), (iii), (iv), (v), (vi), (vii), (viii) and (ix) were correctly selected, suggesting that most of the students had acquired the required skills and knowledge in the respective topics. The item which most of the students selected the wrong alternative was item number (x). In this item most of the students chose alternative 'C' Moment, instead of 'B' Torque. This shows that the students had misconceptions on the product of force and distance from the point in which a body tends to rotate. The students did not understand the concept that torque is a moment that causes a body to revolve around its axis, while moment is the force that causes the body to move (not to rotate). The analysis of students' responses in each item is presented as follows:



- (i) Item (i) was about measurements. It required students to choose five fundamental physical quantities in the SI unit system. The question asked;

*All measurements in engineering science are related to the fundamental quantities. What are the five fundamental physical quantities in the SI unit system?*

- A *Mass, Temperature, Light, Time and Length.*
- B *Time, Length, Mass, Temperature, and Luminous Intensity.*
- C *Length, Density, Temperature, Mass and Time.*
- D *Luminous Intensity, Light, Length, Mass and Temperature.*

Most of the students correctly chose alternative B. *Time, Length, Mass, Temperature, and Luminous Intensity.* These students understood the concepts on the topic of measurements and acquired relevant skills. A few students had confusion with the unit of density so they wrongly chose C. *Length, Density, Temperature, mass and Time.* The students failed to distinguish the unit of density and other fundamental physical quantities which are in SI units. For those who chose A; *Mass, Temperature, Light, Time and Length* and D; *Luminous Intensity, Light, Length, Mass and Tem* did not understand that light has various physical properties like wavelength, intensity and speed whereby some are not fundamental physical quantity such as speed and therefore invalidate it to be a quantity with SI unit.

- (ii) Item (ii) was set from the topic called Simple Machines which required students to evaluate through judging the mechanical advantage when the hydraulic press is frictionless. The question asked;

*An operator man uses a hydraulic press to lift a container. What will be the mechanical advantage, if the hydraulic press is frictionless?*

- A *Greater than velocity ratio*
- B *Small than velocity ratio*
- C *Equal to velocity ratio*
- D *Twice than velocity ratio*

From real life experience and literature reviews any working machine must encounter friction due to resistance exerted by the moving parts. When a machine is frictionless, the mechanical advantage is equal to velocity ratio. In this regard, students who had this knowledge managed

to select the correct answer *C. Equal to velocity ratio*. However, a few had misconceptions, that if there is no friction therefore the velocity ratio would be greater, so they chose *B. Small than velocity ratio*, which is wrong. Some chose *A, Greater than velocity ratio* while others chose *D, twice than velocity ratio*. These students did not know that frictionless machine makes the efficiency of the machine to be 1. That means the input into the machine is equal to the output from the machine, and since

$$\text{efficiency} = \frac{\text{Mechanical Advantage}}{\text{Velocity ratio}},$$

therefore it necessitates the mechanical advantage and velocity ratio to be equal.

(iii) The item number (iii) required students to give examples of the effects of force which can be experienced on a body. The question asked, *Form Two students were arguing about examples of the effects of force which can be experienced on a body. Which is true concerning the effects of forces experienced on body?*

- (i) *A force reduces the speed of a body in motion.*
  - (ii) *A force can cause a body to move faster.*
  - (iii) *Shape can be changed to a new shape by a force.*
  - (iv) *The direction of a moving body can be changed to other direction by force.*
  - (v) *Mass of a body is increased by force.*
  - (vi) *A force can cause damage such as a crack on body.*
- A (i), (ii), (iii), (iv) and (vi)  
 B (i), (ii), (iii), (iv) and (v)  
 C (i), (ii), (iii), (v) and (vi)  
 D (i), (ii), (iii), (v) and (iv)

Majority of the students demonstrated thier understanding on the effects of forces to the body, because they chose the correct answer A. (i) *A force reduces the speed of body in motion*, (ii) *A force can cause a body to move faster*, (iii) *Shape can be changed to a new shape by force*, (iv) *The direction of a moving body can be changed to another direction by force* and (vi) *A force can cause damage to such as a crack on a body*.

However, a few students failed to understand that mass of a body does not vary with respect to place or any forces acting on a body. Therefore, those who lacked enough knowledge on the existence of mass got it wrong by choosing distracters B, C and D which include *mass*. As a

matter of fact, this question required the student to make analysis among the alternatives, therefore for those who were not keen enough to analyse the options and choose the correct one, ended up choosing incorrect options.

- (iv) The item (iv) demanded students to choose an option which best explains how to minimize the problem of friction on machine parts which rub each other. The question asked;

*An engineer observed that, parts of machine rubbing against each other causes friction that leads to unnecessary heat, noise and wear. How can this problem be minimised?*

*A By reducing the speed of the rubbing surface in contact*

*B By increasing the areas of the rubbing surface in contact*

*C By replacing the parts of rubbing surfaces with parts made of graphite material.*

*D By lubricating the rubbing surfaces in contact with grease and oil.*

Most of the students were able to choose the correct alternative which is D. *By lubricating the rubbing surfaces in contact with grease and oil.* This indicates that they had adequate knowledge and skills on the concept of friction. Some of the students were attracted by alternative C, *By replacing the parts of rubbing surfaces with parts made of graphite material.* They chose this alternative because it distracted them, since graphite is a good materials to reduce friction. But they failed to realise that, it is not possible to replace all moving and rubbing parts with graphite materials. They were supposed to understand that, there are other factors that need to be considered in the operating conditions of a machine such as engine cylinder and engine piston which are not made up of graphite. A few students chose alternative A, *By reducing the speed of the rubbing surface in contact* and B, *By increasing the areas of the rubbing surface in contact.* These students lacked knowledge about the material which are used to reduce friction. With regard to the context of the form one and two syllabus, they should know that area and speed of the surfaces in contact do not alter the tendency of friction unless otherwise the friction between the rubbing surfaces is increased.

- (v) Item (v) demanded the students to present the correct feature for a sensitive thermometer. The question asked;

*You are assigned to make a presentation in the class on how to make a sensitive or quick to act thermometer. What features will you consider when manufacturing the thermometer?*

- A A large bulb with a wide capillary tube*
- B Wide capillary in small bulb*
- C Large bulb with a narrow capillary tube*
- D Small bulb with a thin glass wall*

The correct response is *C, Large bulb with narrow capillary tube*. Most of the students chose the correct option. This implies that they had knowledge on the working principle of a quick- acting thermometer whose which its bulb is made up of thin glass so that heat can easily get into the liquid inside the bulb. They further knew that, the *Large bulb with narrow capillary tube* has an effect on the expansion because as the temperature rises, the force of expansion forces the mercury up through the constriction. When the temperature falls, the column of the mercury breaks at the constriction and cannot return to the bulb.

A few students had misconceptions as they chose *D, small bulb with thin glass wall*. They did not know that, the volume of the bulb determines the amount mercury or alcohol entering the capillary tube. The bigger the bulb, the more liquid forced into the capillary and it makes the thermometer more sensitive to change in temperature. Therefore, these students lacked knowledge on how a thermometer is constructed and how it works. A few students chose incorrect alternatives A and B. These students lacked knowledge on the concepts of *sensitive or quick to act thermometer*, thus they were stumbling around and ended up selecting the incorrect options.

- (vi) Item number (vi) was set from the topic called *sound*. The question required students to verify that, sound wave requires a medium for transmission through a source to the observer. The question asked;  
*An electric bell is placed in a vacuum room and starts ringing when switched on. What will be witnessed by an observer outside the room?*
- A The observer will not hear the sound.*
  - B The observer will hear the echo of the sound.*
  - C The observer will hear loud sound.*
  - D The observer will hear some sort of reverberation.*

This item required judgment whether the rung bell inside a vacuum room could be heard by an observer who was outside of the room or not. The correct response to this item is A. *The observer will not hear the sound.* It was noted that most of the students were conversant with the concept of medium through which sound travel from one point to another. A few students who lacked knowledge on the topic of sound chose alternative B, *The observer will hear the echo of the sound.* These students did know that, an echo is a sound that is repeated because the sound waves are reflected back. Therefore, they were supposed to understand that, a vacuum does not allow sound to travel. A vacuum is an area that is devoid of air, such as space. As a result, sound cannot move through space since there is no matter (atoms or molecules) to vibrate and assist sound to travel. Therefore students who chose alternative B, C, and D lacked knowledge on the concepts on the propagation of sound and its properties with respect to medium of transportation. Others allied sound parameters which best describes the topic of sound.

- (vii) In this item, the students were required to identify and apply the correct, measuring instruments for potential difference and electric current in a circuit. The question asked;

*Form two student was assigned to measure the potential difference between the points and an electric current in a circuit. Which measuring instruments should the student have before carrying out the measurements?*

- A A wattmeter and an Ammeter
- B A voltmeter and Wattmeter
- C Voltammeter and an Ammeter
- D A voltmeter and an Ammeter

Most of the students were able to choose the correct response which is D, *A Voltmeter and an Ammeter.* This indicates that these students had acquired the skills for identifying and applying the relevant measuring instrument for a given task. On the other hand, there were students who chose Alternative A, *A Wattmeter and an ammeter,* B, *A voltmeter and wattmeter* and C, *Voltameter and ammeter.* These students chose the

wrong answers because they lacked relevant knowledge on the topic, 'Measuring Instruments' especially on the topic of Electricity and skills on the application of each measuring instruments. They did not understand that, Voltammeter is an instrument that can measure both voltage and current (amps), while voltmeter measures potential difference between two points and wattmeter is a device that measures the active power of electricity.

- (viii) This question was set from the topic *Work, Energy and Power*. The question demanded students to analyse and judge who was right with regard to the arguments made by Maganga, Kazimoto, Gwalu, and Hogoma. The question asked:

*Kazimoto who is a Form Two student was pushing his books cabinet to its position after finishing the cleaning of his room. During this activity his friends Maganga, Gwalu, and Hogoma, who were watching him made a comment?*

- (i) *Maganga said: Good Kazimoto, you are so powerful as you have managed to use your energy with respect to time and power with energy to store the cabinet to its position.*
- (ii) *Gwalu commented to Maganga: Power and energy are two different things, energy is the Power per time taken and power is the ability to do work.*
- (iii) *Hogoma responded to Gwalu: Power is the rate of doing work and energy is the ability to do work.*
- (iv) *Kazimoto commented as well that, energy is the capacity to perform work while power is the energy consumed per time taken.*

*From their arguments, who was right?*

- A *Kazimoto and Gwalu*  
B *Kazimoto and Hogoma*  
C *Gwalu and Hogoma*  
D *Maganga and Kazimoto*

The correct response is B *Kazimoto and Hogoma* whose argument was that, (iii) *Hogoma: responded that power is the rate of doing work and energy is the ability to do work* and (iv) *Kazimoto: energy is the capacity to perform work while power is the energy consumed per time*

*taken*. Choosing the right response indicates that the students were able to make analysis of the four arguments to verify the correct ones. This justifies that they were conversant and had mastery of the concept work, energy and power. The wrong responses provided by a few students indicate that they did not have enough knowledge regarding the definition of the terms ‘work’, ‘energy’. and ‘power’ as they failed to analyse and select the correct options. Those who chose alternative C, did not know that the argument given by Gwalu was incorrect since he gave wrong definition of Power and Energy. He was supposed to write that, ‘Energy’ is the ability to do work and Power is the work done per time taken.

- (ix) This item demanded the students to show the correct formula for a resultant force obtained from the two ropes pulling a heavy concrete slab at an angle of  $90^{\circ}$  in between. The question asked;

*One student was assigned by a teacher to write a formula for calculating resultant force (R) formed by two forces, pulling a heavy concrete slab along a horizontal surface by means of two ropes where the ropes made an angle of  $90^{\circ}$  between them. If the forces in the ropes were  $F_1$  and  $F_2$  respectively which is the correct formula?*

<p>A      <math>R = \sqrt{F_1^2 + F_2^2}</math></p>	<p>B      <math>R = \sqrt{F_1^2 - F_2^2}</math></p>
<p>C      <math>R = \sqrt{F_1 + F_2}</math></p>	<p>D      <math>R = \sqrt{F_1 - F_2}</math></p>

The correct response is A,  $R = \sqrt{F_1^2 + F_2^2}$ . Those who chose the correct response managed to apply the Pythagoras theorem to undertake the resultant force required. They understood that when two forces act on a concrete slab at the same point, the combined effect of these two forces is the same as the effect of a single force called resultant force.

Therefore, they manipulated the vector equation  $R = \sqrt{F_1^2 + F_2^2}$  to obtain the required resultant force. On the other hand, there were a few students, who selected incorrect responses. This indicates that they lacked knowledge and skills on forces, and calculation of vector force acting at  $90^{\circ}$ . This is seen from their failure to apply the Pythagoras theorem to deduce the formula for resultant.

(x) Item (x) was set from a topic of *turning forces*. The question asked;

*Engineering Science teacher presented the diagram shown in Figure 1 on the blackboard and asked the students to give the name of the product of the parameters 'F' and 'a' what will be the student answer to the teacher?*

A Workdone B Torque C Moment D Impulse

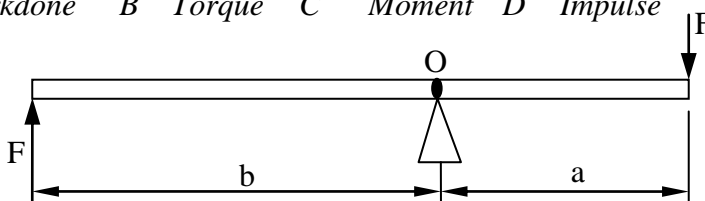

The correct answer is option B, *Torque*. This correct option was selected by few students who were able to differentiate a beam being supported by two or more forces and having opposing forces. These students understood well the concept of torque which is governed by forces causing a body to turn at point. On other side, many students failed to understand that the force which is in one direction in turn brought a turning effect of a horizontal 'swing'. On the contrary these students treated it as beam pivoted by a knife edge, as such they concluded by naming the product 'F' and 'a' as *Moment* by choosing alternative C. The students did not understand that a moment is the product of the perpendicular distance between the point of rotation and the force's line of action while torque is a measure of the turning force of an object. Moment is a static force while torque is a movement force. A few students either chose alternative A or D. Those who chose A confused the product of work and distance which gives a quantity of work done but in this question force 'F' was involved to make a beam turn by two forces. Those who chose D confused the product of force and radius 'a', which gives impulse. It seems they lack knowledge because they did not understand that Impulse is the product of force and time.

### 2.1.2 Question 2: Matching Items - Linear Motion

The question required the students to match the linear motion actions in **List A** with the corresponding parameters in **List B**.



<b>List A</b>	<b>List B</b>
(i) <i>Is a decreasing velocity with time</i>	A Acceleration
(ii) <i>It is a distance in a specific direction</i>	B Change in velocity
(iii) <i>Is a path of an object from one point to another</i>	C Displacement
(iv) <i>Is a rate of change of displacement</i>	D Distance
(v) <i>Is a rate of change of velocity</i>	E Gravitational acceleration
	F Retardation
	G Speed
	H Velocity

This question was attempted by 1673 students (100%). The statistics show that 199 (11.89%) students scored from 0 to 1 mark, 22.47 percent scored from 2 to 3 marks, and 65.63 percent scored from 4 to 5 marks. Figure 3 represent the percentage of scores of the students.

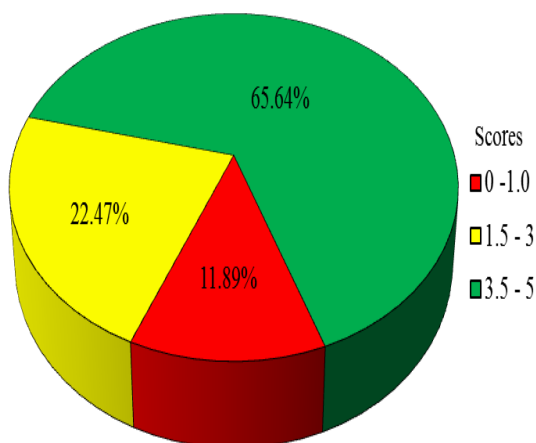

**Figure 3:** Students' Performance in Percentage for Question

As shown in Figure 3, most of the students (65.63%) were able to score 3.5 to 5 marks. Out of these 45.6 percent scored full marks (5 marks). This indicates that the concept of linear motion was well understood by most of the students. The analysis of the students responses in each items is as follows:

- (i) Item (i) required the students to identify the response which matches with the statement; *Is a decreasing velocity with time*. The correct response is F, *Retardation*. Most of the students were able to match this item correctly and a few matched it with an inappropriate responses particularly B, *Change in velocity*. These students did not understand that decreasing velocity with time refers to negative acceleration which

is also called deceleration or retardation. Change of velocity is normal physical quantity with a specified direction.

- (ii) Item (ii) required the students to select the response which matches correctly with the stem; *It is a distance in a specific direction*. The appropriate response was C, *Displacement*. This item was attempted very well by most of the students indicating that measuring of a distance in a specified direction is known and frequently used by many students when calculating velocity and acceleration. On the other hand, a few students who selected inappropriate response by choosing alternative D, *Distance*, suggesting that they lacked knowledge on differentiating distance and displacement. As such distance is the path of an object from one point to another while displacement is the distance in a specified direction.
- (iii) Item (iii), required the students to match the statement, *is a path of an object from one point to another*. The correct response was D, *Distance*. Student who matched it correctly understood that distance measures of the length without specifying the direction. Further analysis on the response of students who matched it wrongly reveals that most of them lacked knowledge on measurement and practical experiences. Others failed to associate distance which is measured from one point to another with distance in a specified direction (displacement) are two different quantities with regard to scalar and vector quantity.
- (iv) Item (iv) required students to identify the response that corresponds correctly write the statement: *Is a rate of change of displacement*. The correct response was H, *Velocity*. This item was attempted well by majority of the students, implying that they were familiar with the term velocity which is the distance moved in a specified direction with respect to time. Other students matched it wrongly as they chose G, *speed*. These students could not differentiate between velocity and speed. Since, speed is distance moved per time and velocity is the rate of change of displacement.
- (v) In item (v), students were required to match the statement, *Is a rate of change of velocity*. The appropriate response was Acceleration. The student who chose the correct response understood that acceleration is the rate of change of velocity. On the other hand, the performance in this item was high as most students responded it correctly. A very few students provided incorrect response since acceleration is commonly employed when calculating distances covered, velocity and time taken

for a moving body in a specified direction. These students lacked knowledge on the concept of linear motion.

## 2.2 SECTION B: Short Answer Questions

### 2.2.1 Question 3: Linear Motion

Question 3 required students to use the data recorded to test a motor car soon after maintenance. From the given data the students were required to (a) calculate the initial velocity and uniform acceleration and (b) determine the final velocity at each round of a test. The recorded data provided were as shown.

<i>Test</i>	<i>Distance in meters</i>	<i>Time taken in seconds</i>
<i>1</i>	<i>30</i>	<i>10</i>
<i>2</i>	<i>42</i>	<i>12</i>

A total of 1673 (100%) students attempted this question, out of which 1471 students (94.86%) scored from 0 to 2.5 marks; 74 students (4.60%) scored from 3 to 6 marks and 9 (0.54%) students scored from 6.5 to 10 marks. Figure 4 represents scores with respect to the percentage of the students.

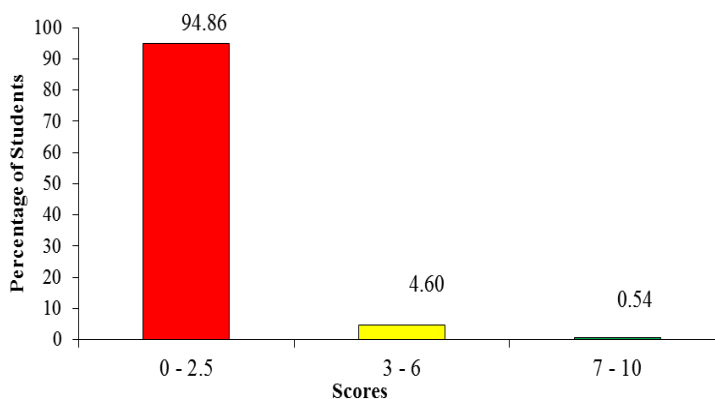

**Figure 4:** Students' Performance in Question 3

Data analysis shows that many students failed to answer this question correctly. Analysis further shows that 94.86% students scored less than 3 marks. Most of them (64.79%) scored 0 mark. From the students' responses

it reveals that the idea of tabulating the linear motion data under two motorcar tests was confused by the students. As a result they failed to remember the formula for the linear motion equation ' $s = ut + \frac{1}{2}at^2$ ', and substitute the data from the table into it. They didn't understand the use of the data in table due to test 1 and 2 as such, therefore they failed to insert them into the linear motion formula. Hence they ended up scoring 0 mark. These students did not know that, they had to insert the data for test 1 and 2 into the formula  $s = ut + \frac{1}{2}at^2$ . Time taken;  $t = 10$  and  $12$  seconds for test 1 and 2 respectively and distance  $s = 30$  and  $42$  m for test 1 and 2 respectively. Therefore, they could obtain  $10u + 50a = 30$  and  $12u + 72a = 42$  as equation (i) and (ii) respectively. These equations could be solved simultaneously for initial velocity ' $u$ ' and ' $a$ ' in part (a). These parameters in turn were to be substituted into the first linear motion formula ' $v = u + at$ ' to obtain the final velocity in part (b). On the other hand, among the students who failed this question scored 2 marks. These students were only able to remember the formula; however, they failed to substitute the data for test 1 and 2 thus scored low marks. Some of the students wrote the correct formula and ended up submitting data without continuing to calculate so they ended up getting poor marks. Generally, the students' performance for this question was poor as shown in a Extract 1.1.

(a) Calculate the initial velocity and uniform acceleration.

Data $d = 30\text{ m}$ $t = 10\text{ s}$	$v_f = 30\text{ m}$ $10\text{ s}$ $v_i = 3\text{ m/s}$	$a = v - u$ $= 42 - 30$ $2$ $= 12$ $2$ $a = 6\text{ m/s}^2$ Uniform acceleration $= 6\text{ m/s}^2$
	$v_f = 3.5\text{ m/s}$ in (b) founded Initial velocity = $3\text{ m/s}$ .	
	Initial velocity = $3\text{ m/s}$ .	

(b) What is the final velocity at each round of a test?

Data Test 1: $d_1 = 30$ $t_1 = 10$	Test 1: $v = \frac{d}{t}$ $v_f = \frac{30}{10}$ $v_f = 3\text{ m/s}$ Final velocity = $3\text{ m/s}$	Test 2: $v_f = \frac{d_1}{t_2}$ $v = \frac{40\text{ m}}{10\text{ s}}$ $v_f = 3\text{ m/s}$ Final velocity = $3.5\text{ m/s}$ $v_f = 3.5\text{ m/s}$
Test 2: $d_2 = 40$ $t_2 = 12$		

**Extract 1.1:** A sample of students' poor responses in Question 3.

The responses in Extract 1.1 indicate that the students failed to apply the relevant formula for linear motion. The students used a velocity formula that includes distance and time instead of formula  $s = ut + \frac{1}{2}at^2$ . This student

ended up calculating the velocity of test 1 and 2 incorrectly.

Further analysis shows that, 5.1 per cent of the students were able to score 3 marks or more. Among them, 4.6 per cent obtained average marks (3 – 6). These students were able to obtain correct answers in some few steps of calculation by writing the formula and submitting the data of test 1 or 2. Other students did not realize that data for test 2 had to be substituted in the same formula as well. They failed to realise that these two formula with data for test 1 and 2 should be manipulated to obtain the two equations which could be solved to obtain initial velocity and uniform acceleration. Therefore, they ended up scoring average marks. Others provided incorrect responses, for example, one student wrote the wrong formula  $v^2 = u^2 + 2as$ . He/she failed to substitute the data and since he/she used wrong formula it would not help to get the initial velocity and uniform acceleration. Others used incorrect formula  $v = u + at$  in part (b) to obtain the value of initial velocity 'u' and uniform acceleration 'a'. They further substituted correct time taken but ended up with wrong answers of final velocity at each round of test.

Moreover, 0.54 percent of the students were able to score high marks (6.5 to 10) marks. Only one student was able to get full (10 marks) allotted to this question. Some of these students were able to write the correct formula and substituted the correct data in part (a) thus getting the correct answer for initial velocity and uniform acceleration. In item (b), most of these students were able to write the correct formula but calculated only to get the final velocity for first round, thus scoring good marks but less than ten. The student who obtained full marks was able to write the formula in part (a) and calculate the initial velocity and uniform acceleration. In turn, he/she used these parameters to find the final velocity. This student had mathematical knowledge and skills as he/she managed to formulate two equations and go through all the calculation steps in part (a). Thus, among other things, he/she seems to have understanding on the topic tested (linear motion). Extract 1.2 shows the student's response.

(a) Calculate the initial velocity and uniform acceleration.

1st test Data  
 $u = 0 \text{ m/s}$   $a =$   
 $v =$   
 $t = 10 \text{ s}$   
 $s = 30 \text{ m}$

Formula  
 $s = ut + \frac{1}{2}at^2$   
 $30 \text{ m} = 0 \text{ m/s} \times 10 + \frac{1}{2} \times a \times 10^2$   
 $30 \text{ m} = \frac{1}{2} \times a \times 100$

$30 \text{ m} = \frac{50a}{50}$   
 $a = 0.6 \text{ m/s}^2$

2nd test data  
 $s = 20 \text{ m}$   $a =$   
 $u = 0 \text{ m/s}$   
 $t = 10 \text{ s}$

Formula  
 $s = ut + \frac{1}{2}at^2$   
 $20 = 0 \times 10 + \frac{1}{2} \times a \times 10^2$

$\frac{20 \text{ m}}{12} = \frac{50a}{12}$   
 $a = 0.58 \text{ m/s}^2$

Total velocity of each test is 0 m/s acceleration of 1st test is 0.6 m/s<sup>2</sup> 2nd test is 0.58 m/s<sup>2</sup>

(b) What is the final velocity at each round of a test?

1st test Data  
 $s = 30 \text{ m}$   $a = 0.6 \text{ m/s}^2$   
 $t = 10 \text{ s}$   
 $v =$   
 $u = 0 \text{ m/s}$

Formula  
 $v^2 = u^2 + 2as$   
 $v^2 = 0^2 + 2 \times 0.6 \times 30$   
 $\sqrt{v^2} = \sqrt{36}$   
 $v = 6 \text{ m/s}$

Final velocity of 1st test = 6 m/s

2nd test Data  
 $s = 20 \text{ m}$   $a = 0.58$   
 $t = 10 \text{ s}$   
 $v =$   
 $u = 0 \text{ m/s}$

Formula  
 $v^2 = u^2 + 2as$   
 $v^2 = 0^2 + 2 \times 0.58 \times 20$   
 $\sqrt{v^2} = \sqrt{23.2}$   
 $v =$

Velocity is 6.98 m/s

**Extract 1.2:** A sample of students' good responses in Question 3.

The Extract 1.2 is a sample of good responses whereby the student applied the correct formula of linear motion. Furthermore, he/she managed to formulate and solve the equations to obtain initial velocity and acceleration.

### 2.2.2 Question 4: Electricity

The question was drawn from the topic Electricity on a sub-topic of leclanche cell. The question required students to do the following;

- (a) *Draw a leclanche cell diagram showing the structure of the cell, and name its four main components.*
- (b) (i) *Briefly explain the effect of the formation of a layer of hydrogen on the positive terminal.*  
(ii) *How can the formation of a layer of hydrogen on the positive terminal in (b)(i) prevented.*
- (c) *Give one advantage and one disadvantage of using the cell.*

A total of 1673 (100%) students attempted this question. Out of these, 1457 (87.09% ) scored from 0 to 2.5 marks; 199 (11.89%) scored from 3 to 6 marks and 17 ( 1.02% ) students scored from 6.5 to 10 marks. Generally, the students' performance in this question was weak. This analysis is summarized in Figure 5.

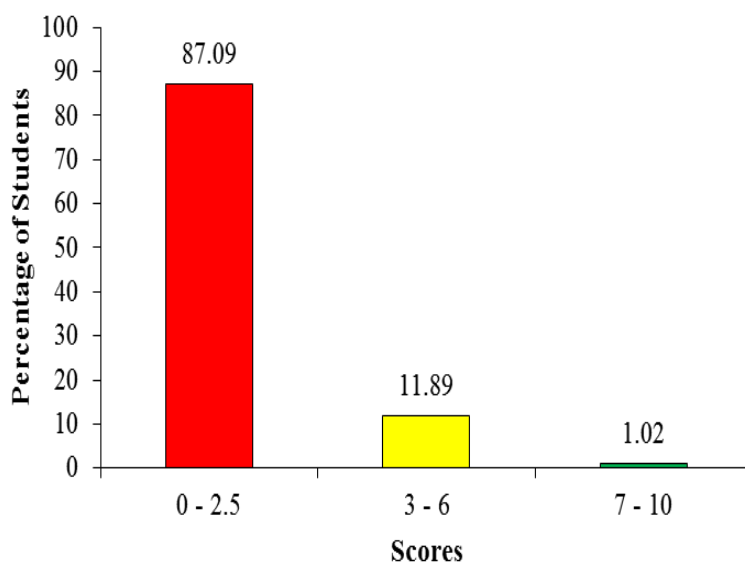

**Figure 5:** Students' Performance in Question 4.

Most of these students (87.09%) performed poorly, scoring less the 3 marks on this question. Whereas 56.01 per cent scored 0 mark. Some of the students had sketched an animal cell instead of a leclanche cell. This indicates that the students confused the knowledge of cell in biology subject with that of Engineering Science. Therefore, these students failed in part (a) and likewise they were not able to answer parts (b) or (c); thus, they got low scores. For

example, one student answered part (c) (i) *it is expensive* as the disadvantage of the cell. Some students answered part (a) correctly but lacked sufficient knowledge and skills to draw a cell. So they failed to draw leclanche cell in parts (b) and (c). Since they failed to give the correct answers in all parts hence they scored either low or zero marks. Extract 2.1 shows a poor response by one of the students.

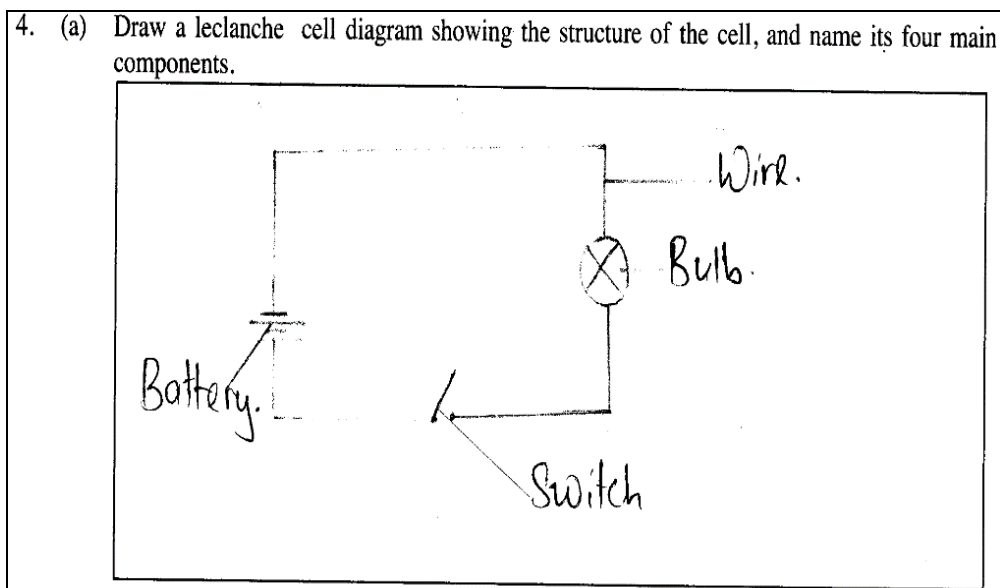

**Extract 2.1:** A sample of student's poor response in a question 4

Extract 2.1 indicates the misconceptions which were encountered by a student. He/she drew an electric circuit instead of a leclanche.

The students who scored an average marks (11.89%) were able to provide correct answers in some parts. There were those who drew a leclanche cell in part (a) but failed to respond appropriately in part (b) and (c). Others failed to draw a leclanche cell in part (a) but provided the correct answers in some portions of part (b) and (c). For example, one student was able to write the correct answers in part (b) (ii) as; *reduced by depolariser chemical* and part (c) advantages of cells such as; *it is inexpensive* and disadvantage as; *It is not possible to recharge this device*.

The analysis shows that students who failed in part (a) faced difficulties in responding this question. This is revealed by their responses of drawing a symbol on a cell instead a diagram of a leclanche cell. Students who



managed to score 2 marks were able to state the advantage and disadvantage of using the cell in part (c), and a few students who scored more than 5 marks were able to draw the structure of the cell.

The smallest group (12.92%) of the students who attempted this question got good marks (6.5 to 10). Some scored good marks of 6.5 to 9.5 and a few scored all 10 marks. All of these had good understanding and skill in the sub-topic of cell though some of them made a few errors in some parts of their responses. For example one student was able to draw a good labelled leclanche cell in part (a) and answered well part (c) except that he/she gave incorrect answers in part (b) (i). He/she wrote *increase emf and decreases the internal resistance of a cell* instead of *decrease of emf and increases the internal resistance of a cell*. Only three students were able to score 10 marks in this question. These students had knowledge and drawing skills related to the topic of electricity especially sub-topic cell. They managed to draw and label the parts of the cell in part (a), also they managed to explain the effect of the formation of a layer of hydrogen on the positive terminal and how to prevent its formation in part (b). These students were also able to write the advantages and disadvantages of using a cell. Their responses confirmed that they had good understanding of the sub-topic cell and its parts as well as the various characteristics of a cell. Extract 2.2 shows a good responses from the student who answered correctly Question 4.

4. (a) Draw a leclanche cell diagram showing the structure of the cell, and name its four main components.

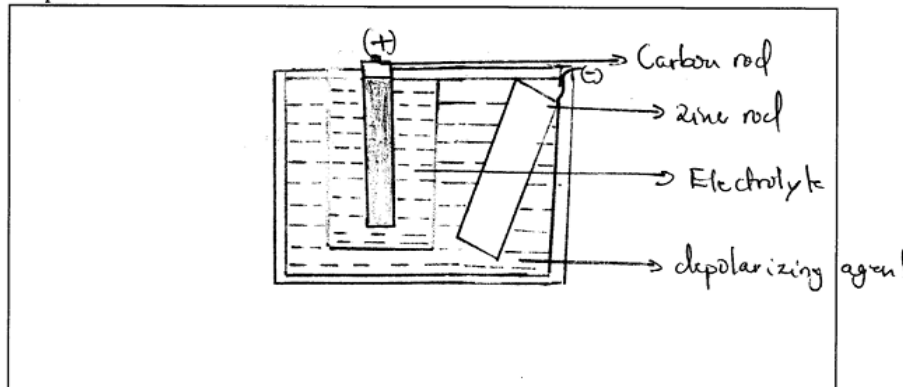

- (b) (i) Briefly explain the effect of the formation of a layer of hydrogen on the positive terminal.

The formation of hydrogen bubbles on the positive terminal causes the resistance to the flow of current hence no electrons or current flow.

4. (a) Draw a Leclanche cell diagram showing the structure of the cell, and name its four main components.

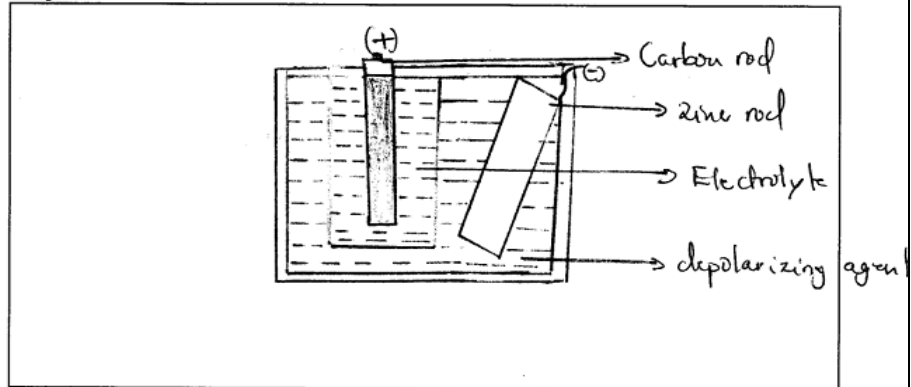

- (b) (i) Briefly explain the effect of the formation of a layer of hydrogen on the positive terminal.

The formation of hydrogen bubbles on the positive causes the resistance to the flow of current hence no electrons or current flow.

- (ii) How can the formation of a layer of hydrogen on the positive terminal in (b) be prevented?

It can only be prevented by introducing depolarizing agent to the cell.

- (c) Give one advantage and one disadvantage of using the cell.

Cell has advantages example it convert stored chemical energy into electric energy when the need of energy arises also it has an advantage when the improperly disposed the pollute the environment.

**Extract 2.2:** A sample of student's good response in Question 4.

The Extract 2.2 depicts a sample of good response provided by a student who attempted this question. This student managed to draw a moderate diagram showing a structure of a cell, stated the advantages of using the cell and was able to explain the effects of hydrogen layer depositing on the positive terminal of a cell.

### 2.2.3 Question 5: Friction

Question 5 was set from the topic Friction and comprised of two parts as follows:

- (a) A form Two teacher wrote the following statement on the blackboard ‘*friction force is directly proportional to the normal reaction between two surfaces in contact with relative motion*’ Derive a mathematical equation represented by this statement.
- (b) Using the formula obtained in (a), find the coefficient of friction where a block of 2kg is pulled on a rough horizontal surface with a force of 15N.

A total of 1673 (100%) students attempted this question, out of which 1457 (62.82%) scored from 0 to 2.5 marks; 199 (14.94%) scored from 3 to 6 marks; and 17 ( 22.24% ) students scored from 6.5 to 10 marks. Generally, the students’ performance in this question was average. Figure 6 presents scores with respect to the percentage of the students.

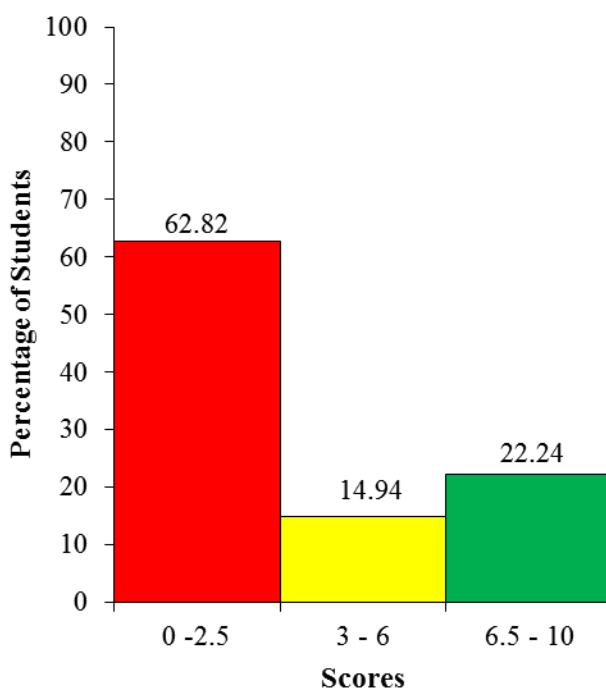

**Figure 6:** Students' performance in Question 5.

Most of the students (62.82%) scored below average with 52.48 per cent scored 0 mark. These students lacked the knowledge on friction which should be used to formulate relationship  $F_r \propto R$  or  $F_r = \mu R$  as was required in item (a). Therefore, their failure to interpret the information to obtain the formula led to failure to do calculation in part (b) which was expected to use formula derived in part (a). Some of the students scored 2 marks in part (a) for being able to write and get the required relation or formula, but they failed to calculate the coefficient of friction because they could not remember that normal reaction should be sought using 'g' acceleration due to gravity therefore they ended up giving incorrect answers and getting below average marks. Extract 3.1 shows poor response by one of the students.

5. (a) A Form Two teacher wrote the following statement on the blackboard "frictional force is directly proportional to the normal reaction between two surfaces in contact with relative motion". Derive a mathematical equation represented by this statement.

is the normal reaction between two surfaces  
 is the move motion black bord

(b) Using the formula obtained in (a), find the coefficient of friction where a block of 2 kg is pulled on a rough horizontal surface with a force of 15N.

data given  
 block friction a block of 2kg  
 force of 15N

2 kg = 10N  
 1kg = 5N

20 N

Soln  
 coefficient of friction  
 $C \cdot F = \text{force} \times \text{block block}$   
 $C \cdot F = 15 \times 20$   
 $C \cdot F = 300 \text{ N}$   
 coefficient of friction = 3000 kg

Extract 3.1: A sample of students' poor responses in Question 5.

Extract 3.1 is a sample of the responses provided by a student who had no idea about friction, as a result he/she could not establish the equation  $F_f = \mu R$ . This student applied meaningless formula to calculate the coefficient of friction and therefore ended up with zero mark.

There were (14.94%) of student who got average marks. Among them, some were able to establish the formula in part (a), to calculate the coefficient of friction in part (b) but did not use 'g' in calculating of reaction force. Others calculated the coefficient of friction with this error which led them to get wrong answer. Others in this group made a mistake in calculation whereby they ended up by getting wrong answer that led to the average score.

Further analysis in this question shows that a few students (22.24%) got good marks (6.5 to 10). Some of these students were able to go through all calculation though they made slight mistake which lead them to score less marks. Some in this group had enough knowledge and skills as they established the formula in part (a) and calculated reaction force, substituted into the formula and obtained the correct value of coefficient of friction  $\mu$  as 0.75. Thus they scored 10 marks.

(a) A Form Two teacher wrote the following statement on the blackboard "*frictional force is directly proportional to the normal reaction between two surfaces in contact with relative motion*". Derive a mathematical equation represented by this statement.

soln

$$F_f \propto R$$

$$F_f = kR$$

whereby

$$k = \mu$$

$$\frac{F_f}{R} = \frac{\mu R}{R}$$

$$\therefore \mu = \frac{F_f}{R}$$

whereby 1

$F_f$  = Frictional force  
 $\mu$  = coefficient of friction force  
 $R$  = Normal reaction.

(b) Using the formula obtained in (a), find the coefficient of friction where a block of 2 kg pulled on a rough horizontal surface with a force of 15N.

Soln

Data Given

Mass = 2 kg

Force = 15N

Coefficient of friction = ?

$$\mu = \frac{F_f}{R}$$

but

$$R = m \times g$$

$$= 2 \text{ kg} \times 9.81 \text{ m/s}^2$$

$$= 19.62 \text{ N}$$

Hence

$$\mu = \frac{15 \text{ N}}{19.62 \text{ N}}$$

$$= 0.76$$

∴ The coefficient of friction is 0.76

**Extract 3.2:** A sample of students' good responses in Question 5.

Extract 3.2 shows how students responded well to the question. The student was able to provide a relationship between frictional force and normal reaction and thereafter managed to write the formula for the coefficient of friction. He/she calculated the reaction force by employing 'g' and then substitute the value for friction force and reaction force. Finally he/she calculated the coefficient of friction correctly.

## 2.2.4 Question 6: Heat

This question was on experiment of expansion of metals, in which a student heated a steel ball to a temperature of  $500^{\circ}\text{C}$  to give a diameter of 50.25 mm. The ball was then placed over a hole of diameter 50 mm. Thereafter, the students were required to estimate the temperature of the ball as a result of dropping it through the hole. (Consider  $\alpha = 0.000012/^{\circ}\text{C}$ ).

A total of 1673(100%) students attempted this question whereas 1267 (75.73%) scored from 0 to 2.5 marks; 228 (13.63%) scored from 3 to 6 marks and 178 (10.64% ) scored from 6.5 to 10 marks. Figure 8 represents scores with respect to the percentage of the students.

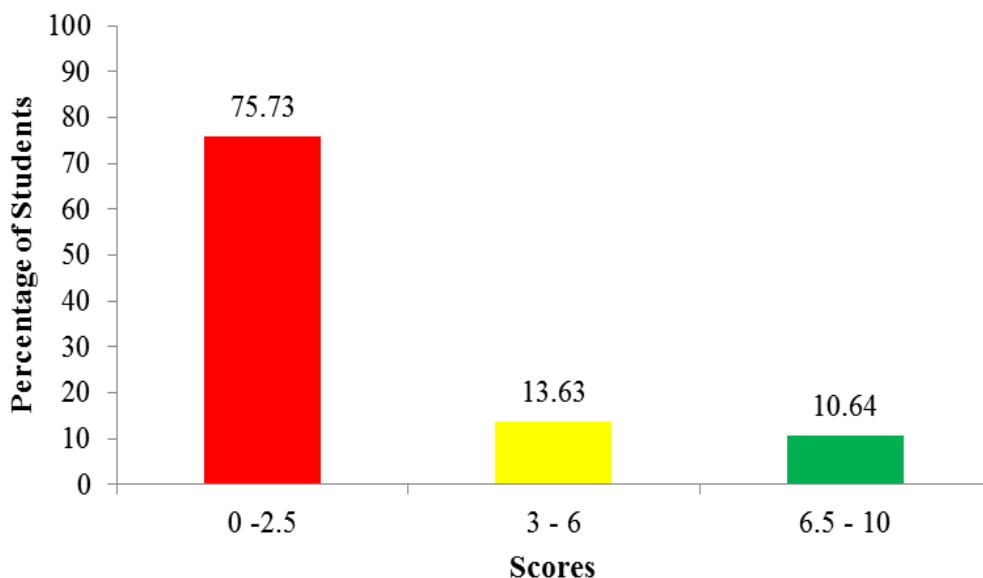

**Figure 7:** Students' Performance in Question 6.

Most of the students (75.73%) scored below 3 marks, out of which 62.40 per cent scored 0 mark. These students could not remember the equation for calculating the coefficient of linear expansion which is  $\alpha = \frac{L_2 - L_1}{L_1(\theta_2 - \theta_1)}$ . This

indicates that they were not familiar with the concept of linear expansion. The analysis shows that, these students lacked the knowledge and ability to; define the coefficient of linear expansion of metal due to heat, demonstrate their ability to experiment and measure the coefficient of linear expansion of various metals and, calculate and obtain coefficient of linear expansion, the



length of steel caused by increasing or decreasing temperatures of metals. Lack of this knowledge and skills led them to develop wrong techniques to describe, experiment to find by calculating parameters related to this sub-topic of expansion of solid materials by using the formula ' $\alpha = \frac{L_2 - L_1}{L_1(\theta_2 - \theta_1)}$ '.

Therefore, this was the reason for them to fail to calculate and obtain the correct answer of the 'final temperature reached' which could enable the ball to penetrate into the hole. However, for those who remembered the equation

$\alpha = \frac{L_2 - L_1}{L_1(\theta_2 - \theta_1)}$  managed to score 2 marks. On the other hand, some who did

not understand the diameter 50.25 mm and 50 mm corresponded to the final length ( $L_2$ ) and initial length ( $L_1$ ) respectively with their corresponding temperatures of  $\theta_2 = 500^\circ\text{C}$  and  $\theta_1$ . Extract 6.1 shows a poor response provided by a student.

6. In an experiment of expansion of metals, a student heated a steel ball to a temperature of  $500^\circ\text{C}$  to give a diameter of 50.25mm. The ball was then placed over a hole of diameter 50 mm. Estimate the temperature of the ball as a result of dropping it through the hole. (consider  $\alpha = 0.000012/^\circ\text{C}$ ).

Solution:

Data given:

Final temperature  $\theta_2 = 500^\circ\text{C}$

Diameter = 50.25mm

hole of diameter = 50 mm

Initial temperature  $\theta_1 = ?$

Specific heat capacity =  $0.000012^\circ\text{C}$

From:

$H = mC\Delta\theta$

$H = 0.000012^\circ\text{C} \times 50\text{mm} (500^\circ\text{C} - 0)$

$H = 6000000 (500)$

$H = 3000000000$

**Extract 4.1:** A sample of student's poor responses in question 6.

Extract 4.1 is a sample answer by a student who confused the formula for linear expansion of metal and the one for heated liquid or mixture of liquid. Instead of using  $\alpha = \frac{L_2 - L_1}{L_1(\theta_2 - \theta_1)}$ , he/she wrote wrong formula,  $H = mC\Delta\theta$ , thus ended up with wrong answer.

Those who scored from 3 to 6 marks (13.63%) managed to write the correct formula for calculating linear expansivity and substituted the given values into the equation correctly. They faced some problems in computation to get the correct diameter of the ball for it to be dropped into the hole. For example one student wrote;  $0.000012 = \frac{50.25 - 50}{500 - \theta_0}$  and obtained the wrong result because he/she did not substitute the original diameter in the denominator therefore ended up scoring average scores.

Despite the fact that many students failed this question, a few (10.64%) students did well. These students scored between 7 and 10 marks since they were conversant with the calculations involving the coefficient of linear expansion. They were able to determine the temperature of the ball after being dropped into the hole. These students were able to write the correct formula for the expansion of metals and followed all the calculation steps to obtain the correct temperature reached. From the responses of these students it reveals that they possessed the knowledge and abilities to establish adequate methodologies for describing, experimenting, and calculating the requisite parameter for this sub-topic of linear expansion of solid materials using the formula. ' $\alpha = \frac{L_2 - L_1}{L_1(\theta_2 - \theta_1)}$ '. As a result, they precisely calculated and acquired the 'final temperature reached' by the ball once it had penetrated the hole. Extract 4.2 is a sample of good response from a student who performed well in this question.

6. In an experiment of expansion of metals, a student heated a steel ball to a temperature of  $500^{\circ}\text{C}$  give a diameter of  $50.25\text{mm}$ . The ball was then placed over a hole of diameter  $50\text{mm}$ . Estimate the temperature of the ball as a result of dropping it through the hole. (consider  $\alpha = 0.000012/^{\circ}\text{C}$ )

Solution:

Data given: Final temperature;  $\theta_2 = 500^{\circ}\text{C}$

Final diameter;  $L_1 = 50.25\text{mm}$

Initial diameter;  $L_0 = 50\text{mm}$

Linear expansivity;  $\alpha = 0.000012/^{\circ}\text{C}$

required: Initial temperature;  $\theta_1 = ?$

$$\text{from: } \alpha = \frac{L_1 - L_0}{L_0 \Delta\theta}$$

$$0.000012/^{\circ}\text{C} = \frac{(50.25 - 50)\text{mm}}{50\text{mm} \times (500 - x)^{\circ}\text{C}}$$

$$0.000012/^{\circ}\text{C} = \frac{50.25 - 50}{50(500 - x)^{\circ}\text{C}}$$

$$\frac{(25000 - 50x)^{\circ}\text{C} \times 0.000012/^{\circ}\text{C}}{25000 - 50x} = \frac{0.25}{50(500 - x)}$$

$$0.3 - 0.0006x = 0.25$$

$$0.3 - 0.25 = 0.0006x$$

$$\frac{0.05}{0.0006} = \frac{0.0006x}{0.0006}$$

$$x = 83.3$$

$$\therefore \text{Temperature} = 83.3^{\circ}\text{C}$$

**Extract 4.2:** A sample of students' good responses in Question 6

Extract 4.2 shows the response by one student who wrote the linear expansion of heated metal formula and substituted the correct data, thus obtaining the correct answer.

### 2.2.5 Question 7: Measuring Instruments

This question was derived from Measuring Instruments. It involved skills of measurements and computation. The question was set as follows:

*Suppose you are given a 100 g of lead shots, measuring cylinder partly full of water to a reading of 80ml. When lead shots placed into it, the reading rose to 88.8ml. Estimate the density and relative density of the lead shots.*

The analysis indicates that 1673 (100%) of the students attempted this question. Among them, 828 (49.49%) scored from 0 to 2.5 marks; 32.82 percent scored zero; 31.32 percent scored from 3 to 6 marks, and 19.19 percent scored from 6.5 to 10 marks. The general performance of the students in this question was average. Figure 8 illustrates this performance.

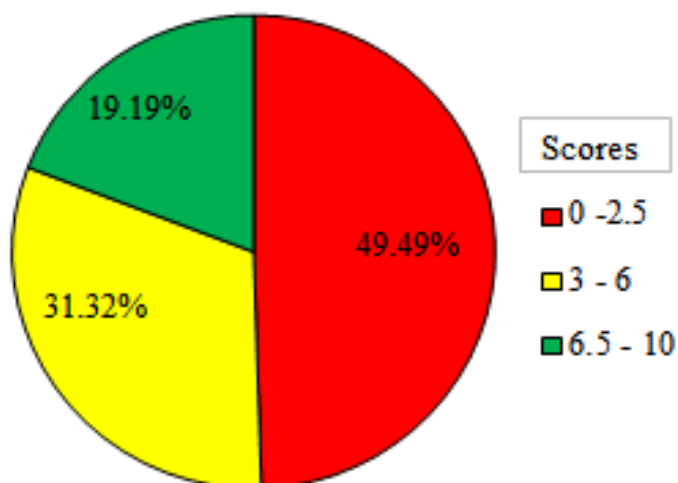

*Figure 8: Students' Performance in Question 7*

The analysis shows that 32.82 percent of the students who scored 0 mark lacked knowledge and skills on measurement of volumes, density, and relative density. Apart from being unable to calculate the volume of the lead shots in the measuring cylinder, they could not subtract the initial reading on the measuring cylinder from the final reading in order to get the volume of lead shots. They also failed to write the appropriate equations for calculating density of lead shots. These students did not know that in order to find relative density they first had to find the density of lead shots and then use this answer to find the relative density by dividing it with a density of water with equal volume as lead shots.

7. Suppose you are given a 100 g of lead shots, measuring cylinder partly full of water to a reading of 80 ml. When lead shots placed into it, the reading rose to 88.8 ml. Estimate the density and relative density of the lead shots.

solution:

Data given:

Given 100g.

Water to a reading = 80ml.

the reading to = 88.8ml

density and relative density of the lead shot?

$$100g \times 80ml \\ = 8000g/ml.$$

$$88.8 \times 800 \\ = 710400 - 88.8 \\ \begin{array}{r} 710400 \\ - 8880 \\ \hline 0510 \\ = 510 \end{array}$$

The density and relative density of lead shot = 510.

**Extract 5.1:** Shows a sample of incorrect response provided by a student in Question 7.

Extract 5.1 represents the responses of a student who multiplied mass x volume to find the density of lead shots instead of density =  $\frac{\text{mass}}{\text{volume}}$ . Moreover he/she failed to find the volume of lead shots which is found by subtracting the two readings, instead he/she used the volume of water 80 ml.

On the other hand there are those who were able to write the density formula but misinterpreted the lead shot density data by dividing the mass of lead shots and the final reading volume of the measuring cylinder with lead shots. This led to wrong answer hence they scored below average.

Another group of students are those who managed to compute the volume of the lead shots, as such they used it to obtain the mass of lead shots and hence calculated the density which they deduced it by the formula, density =  $\frac{\text{mass}}{\text{volume}}$ . Furthermore they used it to calculate the relative density

of lead shots from  $R.D = \frac{\text{density of lead shots}}{\text{density of an equal volume of water}}$ . Most of the

students (6.34%) who reached at this stage of writing these formulae and did correct computation scored 10 marks. Extract 5.2 shows a sample of good response provided by a student.

7. Suppose you are given a 100 g of lead shots, measuring cylinder partly full of water to a reading of 80 ml. When lead shots placed into it, the reading rose to 88.8 ml. Estimate the density and relative density of the lead shots.

Soln.

data given  
 mass of lead shots = 100g (m)  
 Volume of water ( $V_1$ ) = 80 ml  
 Volume of water + lead shots = 88.8 ml ( $V_2$ )  
 density of lead shots = ?  
 relative density of lead shots = ?

from,  
 Volume of lead shots = Volume of water and lead - Volume of water  
 $V_{\text{of lead}} = V_2 - V_1$   
 $V_{\text{of lead}} = 88.8 \text{ ml} - 80 \text{ ml}$

but  
 $1 \text{ litre} = 1000 \text{ ml}$   
 $8.8 \text{ ml} \times \frac{1 \text{ litre}}{1000 \text{ ml}} = 0.0088 \text{ litres}$

but  $1 \text{ litre} = 1000 \text{ cm}^3$   
 $0.0088 \text{ litres} \times 1000 \text{ cm}^3 = 8.8 \text{ cm}^3$

therefore  
 density =  $\frac{\text{mass}}{\text{Volume}}$   
 $\text{density} = \frac{100 \text{ g}}{8.8}$   
 $\text{density} = 11.36 \text{ g/cm}^3$   
 $1 \text{ g/cm}^3 = 1000 \text{ kg/m}^3$   
 $11.36 \text{ g/cm}^3 = 11360 \text{ kg/m}^3$

But  
 $R.D = \frac{\text{density of lead}}{\text{density of water}}$   
 $R.D = \frac{11360 \text{ kg/m}^3}{1000 \text{ kg/m}^3}$   
 $R.D = 11.36$   
 $\therefore$  relative density is 11.36  
 $\therefore$  density is 11360 kg/m<sup>3</sup> or 11

**Extract 5.2:** A sample of good response provided by a student who answered correctly question 7.

Extract 5.2 indicates a sample of good responses provided by a student who scored full marks allotted to this question. He/she had mastery on the topic and computation skills.

## 2.2.6 Question 8: Simple Machines

This question had two parts (a) and (b). In part (a) the students were asked to arrange the following equipment: Wheelbarrow, Scissors, Spade, Nut Cracker, Tong and Fishing rod according to their classes of lever. In part (b), students were required to find the mechanical advantage for a lever used to lift a heavy iron block from one point to another during cleanliness session in the workshop. A load was placed 15 cm away from a fulcrum and effort was applied to the other side of the lever 90 cm away from the fulcrum.

A total of 1673 (100%) students attempted this question, out of which 484 (28.93%) of the students scored from 0 to 2.5 marks; 640 (38.25%) scored from 3 to 6 marks, and 549 ( 32.82% ) students scored from 6.5 to 10 marks. Generally, the students' performance in this question was good. Figure 9 presents scores with respect to the percentage of the students.

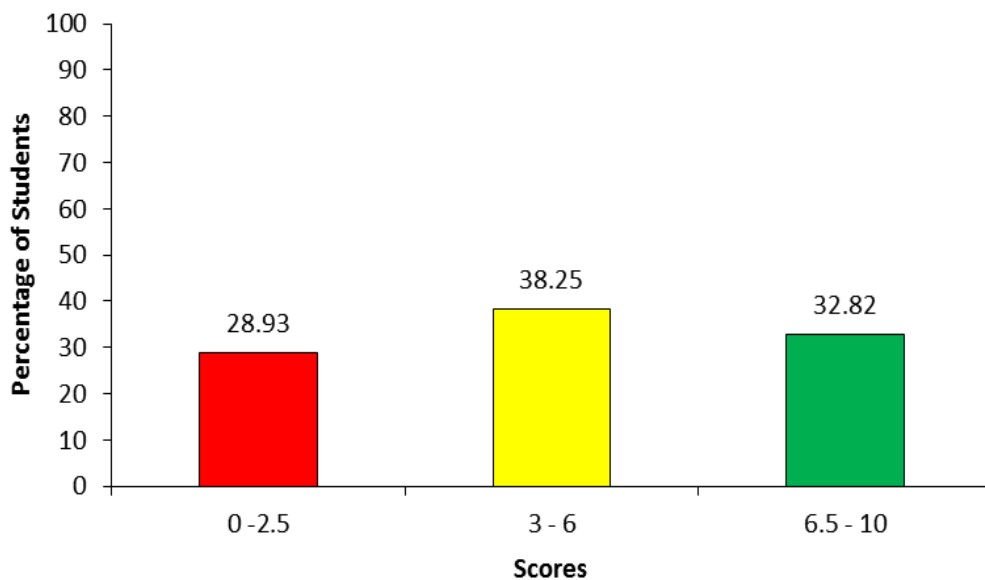

**Figure 9:** *Students' Performance in Question 8.*

The analysis shows that 22 students (1.3%) obtained 10 marks allotted to this question. The analysis found that in part (a), these students were able to arrange the instruments given to their classes of lever. The tricky part in this question was to realize that the instruments with the fulcrum in the middle belong to the first class of lever, the instruments with the load at middle belong to the second class of lever and the instruments with the effort at the middle between fulcrum and load belong to the third class of lever. Further analysis shows that many students had an understanding and knowledge on

the concept tested. They were able to classify the instrument given in respective to the class levers by associating loads, fulcrum and effort positions respectively. These students were able to relate the load, fulcrum and effort of these instruments to their lever classes. For example, with scissors, fulcrum is between load and effort so they arranged it correctly in the first classes. Wheelbarrow and nut cracker the loads are in the middle between fulcrum and effort hence they placed these instruments in the second class of lever. Spade, fishing rod and tong, efforts are applied on these instruments when they are at middle between fulcrum and load where these instruments were arranged in the third class of lever. So these students had enough understanding regarding to the sub-topic levers which in the topic simple machine and were able to answer this question with regard to its requirements.

In part (b), students managed to apply the concept of the principle of moment to establish that a lever works on the principle of moments. They were able to make assumption that the lever is weightless and frictionless and in the equilibrium position of the lever, the moment of load about the fulcrum is equal to the moment of the effort applied about the fulcrum. Furthermore, they were able to apply the principle of moments to establish mathematical relation about a point such as  $L \times 15 = E \times 90$ . Thus they applied the principle of moments to establish relation about a point  $\frac{L}{E} = \frac{90}{15} = 6$ . Among those who scored full marks, there were (31.50%) of the students who got the highest (6.5 to 9.5) marks. Most of these students were able to arrange a few instruments in their respective class of lever in part (a). Others mixed these instruments in their group with respective class. For example one student mixed up by writing *Spade and tong belong to the first class of lever* instead of the third class of level and *the Fishing rod and Wheelbarrow belong to the first class instead of second class of lever*. In item (b), they were able to apply the principle of moment and calculated correctly and got marks for this part.



8. (a) An engineering science laboratory teacher received the following equipment: wheelbarrow, scissors, spade, nut cracker, tong and fishing rod. Arrange these equipment according to their classes of lever.

Soln

First class lever	Second class lever	Third class lever
- Scissors	- wheel barrow	- Spade
-	- nut cracker	- tongs
		- fishing rods

- (b) A student used a lever to shift a heavy iron block from one point to another during cleanliness session in the workshop as shown in Figure 2. Calculate the mechanical advantages of this lever.

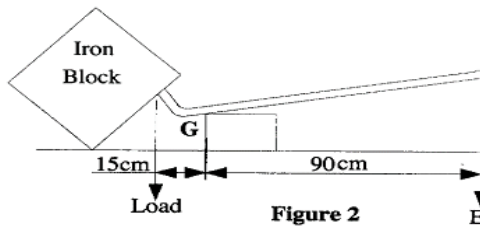

Soln

data given

Load distance = 15cm

effort distance = 90cm

Load = ?

effort = ?

M. advantage = ?

from the formula

$$\text{mechanical advantage} = \frac{\text{Load}}{\text{Effort}}$$

but

$$\text{Load} \times \text{Load distance} = \text{effort} \times \text{effort distance}$$

$$\text{Load} \times 15\text{cm} = \text{Effort} \times 90\text{cm} \quad (\text{divide both sides the effort})$$

$$\text{Load} \times 15\text{cm} = \frac{\text{Effort} \times 90\text{cm}}{\text{effort}}$$

$$\text{Effort}$$

$$\text{Load} = \frac{90\text{cm}}{15\text{cm}}$$

$$\text{Effort}$$

whereby  $\frac{\text{Load}}{\text{effort}} = \text{mechanical advantage}$

$$\text{mechanical advantage} = \frac{90\text{cm}}{15\text{cm}}$$

$$MA = 6$$

∴ the mechanical advantage is 6.

**Extract 6.1:** A sample of good response provided by a student who answered correctly.

Extract 6.1 shows the good responses provided by one of the students who attempted this question. This student managed to apply the principle of moments and computed Mechanical Advantage (MA) as demanded in the question.

Further analysis shows that, some 35.25% of the students obtained average (3 to 6) marks in this question. Among these students, there were those who managed to arrange instruments in first class, second and third class in part (a) correctly but failed to apply the principle of moment to calculate the mechanical advantage thus obtaining average marks. There were those who were able to arrange first or second class in item (a) and did well in some parts of part (b) so they got average marks as well. On the other hand, there were those who attempted only part (b) and were able to calculate some parts of the question, thus got average marks in this question.

However some of the students (28.93%) scored low marks in this question. Some of them (12.13%) scored 0 marks since they failed to classify the equipment according to their classes. They also failed to write the correct equation for calculating Mechanical Advantage (MA) which is obtained by giving the formula  $M.A = \frac{Load}{Effort}$ . From the students' responses, it is revealed

that, this group of students lacked knowledge and skills on identifying the three classes of levers in part (a). Hence students failed to identify and group the given equipment to their respective class of levers. This situation shows that these students lacked sufficient knowledge in the sub-topic classes of levers. In part (b), students were not conversant with the applications of levers in everyday life as a results they were not able to determine the mechanical advantage of a lever. Extract 6.2 shows an example of poor response from one of the students.

8. (a) An engineering science laboratory teacher received the following equipment: wheelbarrow, scissors, spade, nut cracker, tong and fishing rod. Arrange these equipment according to their classes of lever.

i. wheelbarrow  
 ii. Scissors  
 iii. Spade  
 iv. Arrange these equipment according to their classes of lever  
 v. tong and fishing rod.

- (b) A student used a lever to shift a heavy iron block from one point to another during cleanliness session in the workshop as shown in Figure 2. Calculate the mechanical advantages of this lever.

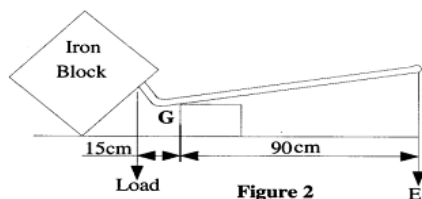

Soln

$$15\text{cm} + 90\text{cm} = 105$$

$$105 = 2$$

$$90$$

$$140 + 180 = 270$$

$$G = 270$$

i. Iron

ii. block

**Extract 6.2:** A sample of poor responses provided by a student who answered incorrectly.

In Extract 6.2, a student wrongly wrote the instruments by jotting them down instead of arranging them into their respective classes of lever in part (a). In part (b), he/she failed to write any correct formula and ended up obtaining wrong answer.

### 2.2.7 Question 9: Work, Energy and Power

This question was set from the topics Work, Energy, and Power. The question had three parts which were stipulated as follows:

- (a) A motor vehicle technician was servicing an engine in an automotive garage. He noted that the engine has mass of 150 kg

- and suspended by a crane with 4m above the ground. Determine the potential energy due to its position.*
- (b) *If the engine in (a) falls to the ground from that height; Calculate the velocity and kinetic energy of the engine at the point of impact with the ground.*
- (c) *Determine the kinetic energy and the potential energy of the engine after falling 3m. Neglect air resistance.*

This question was attempted by (100%) students. Among them, 39.87 percent scored from 0 to 2.5 marks of whom 34.61 percent scored 0 mark; 34.31 percent scored from 3 to 6 marks, and 25.82 percent scored from 6.5 to 10 marks. This is one of the questions that were averagely performed. The graphical presentation of the groups of scores with respective percentage of students who attempted this question is as shown in Figure 10.

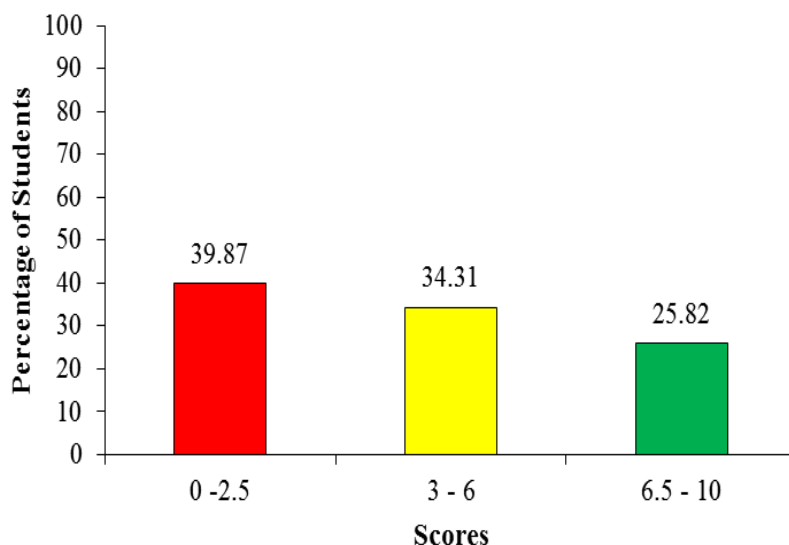

**Figure 10:** Students' performance in Question 9

The analysis shows that 51 (3.0%) students scored ten (10) marks allotted to this question. These students were able to use the formula  $PE = mgh$ ,

$KE = \frac{1}{2}mv^2$  and  $v^2 = u^2 + 2gh$  to calculate the potential energy, kinetic energy and the velocity of the engine just before it strikes the ground respectively. In addition, these students understood that when an object falls from a certain height above the ground, the loss of potential energy is equal to the gain of kinetic energy at any particular point. That is, energy lost in

potential is equal to total potential energy minus kinetic energy gained. There were those who scored average marks. These only managed to attempt correctly some of the parts therefore they got average marks. For example one student was able to write the formulae in part (a) and (b) and got the correct answers, but he/she failed to attempt well the question in part (c), because he/she failed to know the trick of calculating KE of engine at the point of impact with the ground.

9. (a) A motor vehicle technician was servicing an engine in an automotive garage. He noted that the engine has mass of 150 kg and suspended by a crane with string 4 m above the ground. Determine the potential energy of the engine due to its position.

Given

$$\text{Mass of engine} = 150 \text{ kg}$$

$$\text{Height of the crane} = 4 \text{ m}$$

$$\text{gravitation force} = 10 \text{ N/kg} = 9.81 \text{ N/kg}$$

$$\text{potential energy (p.E)} = ?$$

from

$$\begin{aligned} \text{p.E} &= \text{Mass} \times \text{gravity} \times \text{height} \\ &= mgh \\ &= 150 \times 9.81 \times 4 \end{aligned}$$

$$\begin{aligned} \text{p.E} &= 150 \times 9.81 \times 4 \\ &= 15 \times 981 \times 4 \\ &= 5,886 \text{ J} \end{aligned}$$

$$\begin{aligned} \text{The potential energy due to its position} \\ &= 5,886 \text{ J.} \end{aligned}$$

- (b) If the engine in (a) falls to the ground from that height; Calculate the velocity and kinetic energy of the engine at the point of impact with the ground.

From the principle of conservation of energy

$$\text{But } \text{p.E} = \text{K.E}$$

$$\text{where } \text{K.E} = \frac{1}{2} mv^2$$

$$\text{mgh} = \frac{1}{2} mv^2$$

$$\frac{1}{2} mv^2 = mgh$$

$$\left( \frac{1}{2} \times 150 \times v^2 \right) = (150 \times 9.81 \times 4)$$

$$\frac{150v^2}{150} = \frac{(150 \times 9.81 \times 4)}{150}$$

$$\sqrt{v^2} = \sqrt{(9.81 \times 4) \times 2}$$

$$v = \sqrt{78.48}$$

The velocity on the impact with the ground =  $\sqrt{78.48} \text{ m/s}$ .

$$\text{K.E} = \frac{1}{2}mv^2$$

$$= \frac{1}{2} \times 150 \times \sqrt{78.48} \times \sqrt{78.48}$$

$$= 75 \times 78.48$$

$$= 5886 \text{ J}$$

(The K.E = 5,886 J.)  
The kinetic energy of the body = 5,886 J.

(c) Determine the kinetic energy and the potential energy of the engine after falling 3m. Neglect air resistance.

Given  
Initial height = 4m  
Final height = (4-3)m = 1m  
K.E = ?  
P.E = ?

from P.E = mgh  
= 150 × 9.81 × 1  
= 1471.5 J

The potential energy of the body after falling 3m = 1471.5 J.

From total energy of the body = 5,886 J

On falling ~~3m~~ some of the P.E were changed into K.E. After falling 3m, 1471.5 J of energy were still P.E the other energy is already changed to K.E

$$\text{K.E at 3m} = \text{total energy} - \text{P.E at 1m}$$

$$= 5,886 - 1471.5$$

$$= 4,414.5 \text{ J}$$

The K.E of the body after falling 3m = 4,414.5 J.

**Extract 7.1:** A sample of good responses from one of the students' script.

Extract 7.1 is a sample of students' responses who performed well in this question. He/she had knowledge and skills on the topic Work, Energy, and Power. He/she managed to state the principle of conservation of energy and was able to calculate PE and KE of engine at the point of impact with the ground.

Those who scored zero in this question could not remember any of the formula;  $PE = mgh$ ,  $KE = \frac{1}{2}mv^2$  and  $v^2 = u^2 + 2gh$ . These students did not understand that, when a body falls from a certain height (h) above the ground, potential energy lost is equal to kinetic energy gained. Therefore they failed to establish any mathematical calculation as a result they scored zero. Extract 7.2 shows the poor responses provided by one of the students.

9. (a) A motor vehicle technician was servicing an engine in an automotive garage. He noted that the engine has mass of 150 kg and suspended by a crane with string 4 m above the ground. Determine the potential energy of the engine due to its position.

Soln

Potential energy =  $\frac{\text{Mass}}{\text{height}}$

Potential energy =  $\frac{150\text{kg}}{4\text{m}}$

Potential energy =  $37.5\text{kg/m}$ ,  $37.5\text{kg/m}^2$

(b) If the engine in (a) falls to the ground from that height; Calculate the velocity and kinetic energy of the engine at the point of impact with the ground.

Velocity =  $\frac{\text{Acceleration due to gravity}}{\text{Height}}$

=  $\frac{9.81\text{m/s}^2}{4\text{m}}$

=  $2.31\text{s}^2$

Velocity =  $2.31\text{s}^2$

Kinetic Energy =  $\text{Acceleration due to gravity} \times \text{height}$

=  $9.81\text{m/s}^2 \times 4\text{m}$

=  $39.24\text{m/s}^2$

- (c) Determine the kinetic energy and the potential energy of the engine after falling 3m. Neglect air resistance.

$$\text{Kinetic energy} = \frac{Mv^2}{2} = \text{Acceleration due to Gravity} \times \text{height}$$

$$9.81 \text{ m/s}^2 \times 3 \text{ m}$$

$$29.43 \text{ m/s}^2$$

$$\therefore \text{KE} = 29.43 \text{ m/s}^2$$

$$\text{Potential energy} = \frac{\text{Acceleration due to gravity} \times \text{Height}}{2}$$

$$\frac{9.81 \text{ m/s}^2}{2}$$

$$3.27 \text{ s}^2$$

$$\text{PE} = 3.27 \text{ s}^2$$

Extract 7. 2: A sample of poor responses from one of the students' script.

Extract 7.2 shows a poor responses provided by one of the students who failed demonstrate his/her understanding in the topic. The student failed even to equate potential energy ( $\text{P.E} = mgh$ ) and kinetic energy ( $\text{KE} = \frac{1}{2}mv^2$ ). Thus he/she scored 0 mark.

## 2.3 SECTION C: Structured Question

### 2.3.1 Question 10: Electricity

The question involved practical aspect as follow:

A form two student prepared an experiment in laboratory to determine the resistance 'R' of a metallic conductor. She closed the switch K, and adjusted the rheostat 'R<sub>n</sub>' to different positions to increase the current. For each position she recorded the readings 'V' and 'I' of the voltmeter and ammeter respectively.



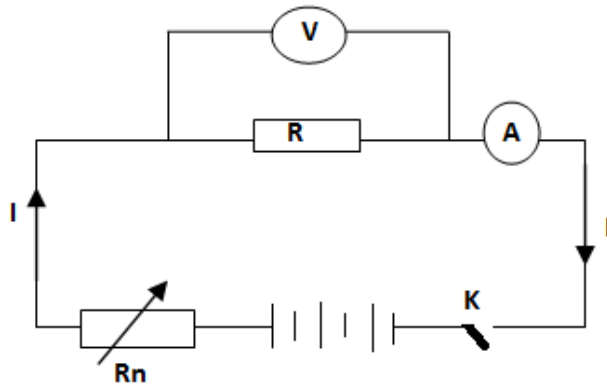

I (Amp)	1	2	3	4	5	6
V (Volts)	2	4	6	8	10	12
$\frac{V}{I}$						

From the Table 2 answer the following questions.

- Find the ratio  $\frac{V}{I}$  for each pair and fill the Table 2.
- Plot the graph of  $V$  against  $I$
- Calculate the gradient 'S' of the graph drawn in (b)
- Compare the value of the gradient 'S' obtained in (c) and the values of the ratio  $\frac{V}{I}$  obtained in (a).
- State the relation between  $S$  and  $\frac{V}{I}$
- Which physical quantity is represented by the gradient 'S'?
- Determine the value of the resistance 'R' of the metallic conductor.

This question was attempted by 1673 (100%) students. Among them, 43.99 percent scored from 0 to 2.5 marks; 19.90 percent scored 0 mark; 25.70 percent scored from 3 to 6 marks, and 30.30 percent scored from 6.5 to 10 marks. This is one of the questions that was averagely performed. The graphical presentation of the groups of scores with respective percentage of students who attempted this question is in Figure 9.

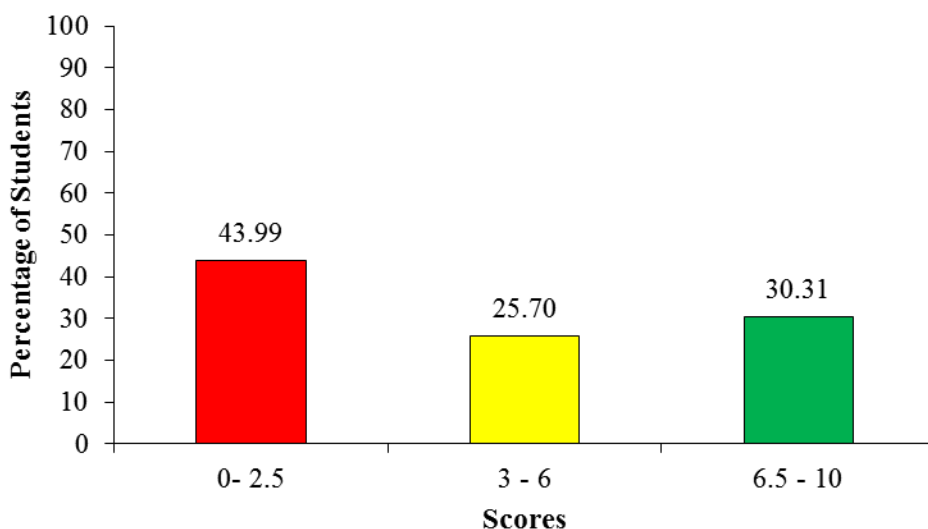

**Figure 11:** *Students' Performance in Question 10.*

Most of the students attempted part (a) successfully, except those who were not familiar with the topic *Electricity*. The analysis shows that 56.01 per cent of the students scored 3 marks and above. Only a few (7.47%) managed to provide correct answers to all parts of the question. Thus, they scored full marks. These students manage to find the ratio  $\frac{V}{I}$  and filled in the table provided in part (a). In this item, they plotted the graph of V against I. In part (c) they also were able to state that the values of the gradient 'S' obtained which is equal to the values of the ratio obtained in part (a). In addition, they managed to identify the physical quantity represented by 'S' as the resistance 'R' of the conductor. Furthermore, they were able to determine the value of the resistance 'R' as  $2\Omega$ . These students succeeded to score fifteen (15) marks allotted to this question. Some of the students were able to perform the large portion of the question, but made minor mistakes in some parts thus they scored between 6.5 and 9.5 marks.

- Find the ratios  $\frac{V}{I}$  for each pair and fill Table 2.
- Plot the graph of V against I.
- Calculate the gradient 'S' of the graph drawn in (b).
- Compare the value of the gradient 'S' obtained in (c) and the values of the ratio  $\frac{V}{I}$  obtained in (a).
- State the relationship between S and  $\frac{V}{I}$ .
- Which physical quantity is represented by the gradient 'S'?
- Determine the value of the resistance 'R' of the metallic conductor.

10

(a)

V (volts)	2	4	6	8	10	12
I (Amp)	1	2	3	4	5	6
$\frac{V}{I}$	2	2	2	2	2	2

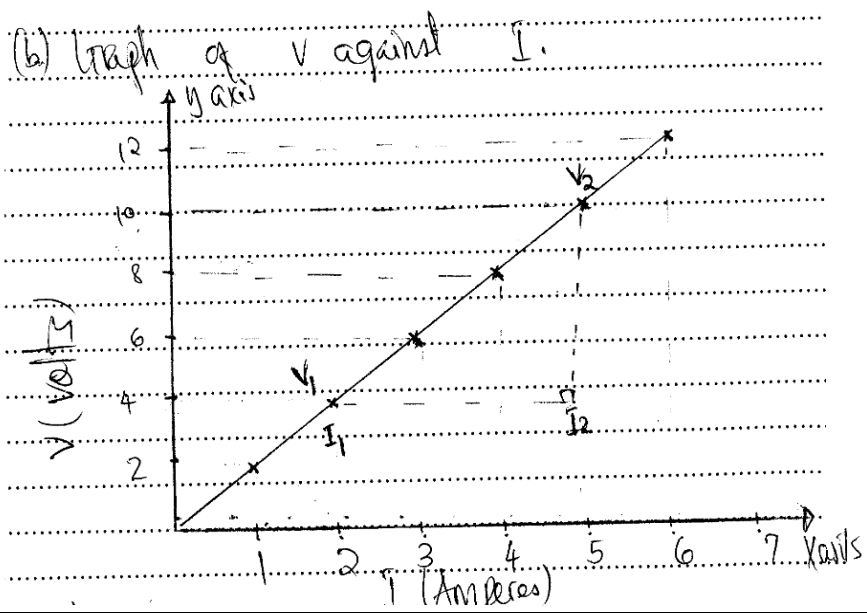

$$10.(c) \text{ gradient} = \frac{\text{change of vertical height}}{\text{change of horizontal line}}$$

from the graph

$$\text{gradient } S = \frac{\text{change of } V}{\text{change of } I}$$

$$= \frac{V_2 - V_1}{I_2 - I_1}$$

$$= \frac{10 - 4}{5 - 2}$$

$$= \frac{6}{3}$$

The gradient 'S' from the graph = 2.

10.(d) The ratio of  $V/I$  obtained in  $a = 2$   
The value of gradient S from graph = 2

By comparison

The ratio of  $V/I$  equals to the gradient S from the graph.

$$V/I = \text{gradient.}$$

10. (e) from comparison on 10 (d) above

$$\text{gradient } S = \frac{V}{I}$$

$$S = \frac{V}{I}$$

$$\frac{S}{1} = \frac{V}{I}$$

$$S I = V$$

$$V = S I \quad \dots (i)$$

from  $V = S I$

$$I = \frac{V}{S} \quad \dots (ii)$$

The relationship between  $S$  and  $\frac{V}{I}$

$$S = \frac{V}{I} \quad \dots (i)$$

$$V = S I \quad \dots (ii)$$

$$I = \frac{V}{S} \quad \dots (iii)$$

10. (f) The physical quantity represented by the gradient  $S =$  Resistance (R).

$S$  represents Resistance (R) of the conductor.

10. (g) The value of  $R$   
from 10 (f) above  
 $S$  represents  $R$

$$\begin{aligned}
 \text{Bot } S &= R \\
 S &= \text{gradient} \\
 \text{gradient} &= \frac{\Delta V}{\Delta I} \\
 &= \frac{10 - 4}{5 - 2} \\
 &= \frac{6}{3} \\
 &= 2 \\
 \text{Bot gradient (S)} &= 2 \\
 \text{The value of resistance (R) of the metallic conductor} &= 2\Omega.
 \end{aligned}$$

**Extract 8. 1:** A sample of good responses from one of the student.

Extract 8.1 indicates a good responses provided by one of the students who attempted this question. This student managed to verify the Ohm's Law through linking the formula  $R = \frac{V}{I}$ , as such they managed to determine the value of the resistance 'R' to be  $2\Omega$ .

There were students who got average marks. These students were able to write the correct answers to some parts of the question thus they got average marks. Many of these students incorrectly attempted parts (d) to (g). They were unaware that, the value of the ratio  $\frac{V}{I}$  is equal to the value of the gradient 'S' while relationship between S and  $\frac{V}{I}$  is,  $S = \frac{V}{I}$ , Thus the physical quantity represented by 'S' is the resistance R and the size of the resistance R is equal to the gradient 'S' of the graph.

Students who scored 0 mark failed even to make correlation of the data and find the value of the ratio  $\frac{V}{I}$  in the entire row of the table provided. For example, one student incorrectly filled in the table in part (a) and was not able to draw the graph of V against I in part (b). He / she also failed to find the gradient 'S' of the graph required to be drawn. The mistake he/she made was to fill in incorrectly the table in part (a) and was not able to draw the graph because he/she interchanged the data for V into I and vice versa therefore he/she scored zero mark.

$\frac{V}{I}$	0.5	0.5	0.5	0.5	0.5	0.5
---------------	-----	-----	-----	-----	-----	-----

Find the ratios  $\frac{V}{I}$  for each pair and fill Table 2.

Plot the graph of V against I.

Calculate the gradient 'S' of the graph drawn in (b).

Compare the value of the gradient 'S' obtained in (c) and the values of the ratio  $\frac{V}{I}$  obtained in (a).

State the relationship between S and  $\frac{V}{I}$ .

Which physical quantity is represented by the gradient 'S'?

Determine the value of the resistance 'R' of the metallic conductor.

(a) soln

$$\frac{1}{2} = \frac{2 \overbrace{10}^{0.5}}{\overbrace{10}^{0.5}} = 0.5$$

$$\frac{2}{4} = \frac{4 \overbrace{20}^{0.5}}{\overbrace{20}^{0.5}} = 0.5$$

$$\frac{2}{2} = \frac{2 \overbrace{10}^{0.5}}{\overbrace{10}^{0.5}} = 0.5$$

$$\frac{4}{8} = \frac{8 \overbrace{40}^{0.5}}{\overbrace{40}^{0.5}} = 0.5$$

$$\frac{5}{10} = \frac{10 \overbrace{50}^{0.5}}{\overbrace{50}^{0.5}} = 0.5$$

$$\frac{6}{12} = \frac{12 \overbrace{60}^{0.5}}{\overbrace{60}^{0.5}} = 0.5$$

(b)

V	1	2	3	4	5	6
I	2	4	6	8	10	12

(c)  $\frac{1}{2} = 2 \frac{0.5}{10}$   
 = So the gradient "s" is 0.5 Ohms

(d)  $s = \frac{V}{I} = \frac{1}{2}$   
 $s = \frac{1}{2} = \frac{1}{2}$   
 $0.5 = 0.5$   
 Ans = Are the same 0.5

(e)  $s = \frac{V}{I}$   
 $\frac{V = sI}{I \quad I}$   
 $\underline{\underline{s = \frac{V}{I}}}$

(f) Resistor

(g)  $R = \frac{V}{I}$   
 $R = \frac{1}{2}$   
 $R = 0.5 \text{ Ohm}$

**Extract 8. 2:** A sample of poor response from one of the students' script.

Extract 8.2 is a sample of poor responses provided by one of the students who attempted this question. This student failed even to complete the table by computing the ratio  $\frac{V}{I}$  from the given data in order to fill the entire row. Also he/she did not have skills to draw the graph of V against I.



### **3.0 THE STUDENTS' PERFORMANCE IN EACH TOPIC**

Ten (10) questions from various topics of form I and II were included in the 2021 FTNA Engineering Science assessment. The analysis of the performance indicates that questions 1 and 8 had good performance since the percentages of the students who passed were 88.11 and 71.07 respectively. Question 1 was multiple choice question set from the topics of *Measurement, Simple Machine, Force, Friction, Heat, Sound, Electricity, Work, Energy and Power, and Turning Force* and question 8 was set from the topics of *Simple Machine*.

The questions which were performed averagely were from the topics of *Work, Energy and Power* (60.13%), *Fluid Mechanics* (50.51%), *Linear Motion* (46.63%), *Electricity* (42.41%) and *Friction* (37.18%).

Furthermore, the analysis shows that, the remaining one question had weak performance as most of the students scored below 30 percent. This question was set from the topic of *Heat* (24.27%). Appendix 1 summarises the students' performance in each topic, and is represented in colours where red, yellow and green colours represents weak, average and good performance respectively.

### **4.0 CONCLUSION AND RECOMMENDATION**

#### **4.1 Conclusion**

Base on the student's analysis of each question, it can be concluded that the overall performance in Engineering Science subject for the 2021 Form Two National Assessment (FTNA) was average. That is, 53.62 percent of the students passed the assessment.

The majority of the students had good performance in Question 1 comprising the topics of *Measurement, Simple Machine, Force, Friction, Heat, Sound, Electricity, Work, Energy and Power, and Turning Force* and 8 from the topic of *Simple Machine*. They had an average performance in Questions 9 from the topic *Work, Energy and Power*, 7 from the topic *Fluid Mechanics*, 2 and 3 from the topic of *Linear Motion*, 4 and 10 from the topic *Electricity* and 5 from the topic of *Friction*. Weak performance was observed in Question 6 from the topic *Heat*. The reason of failure in some

of these topics tested is lack of knowledge, failure to remember laws, theories and principles and inability to follow calculation processes or steps.

## 4.2 Recommendation

From the students' weakness observed in this analysis, it is recommended that;

- (a) Teachers should adhere to the principles of conducting competence based assessment during teaching and learning process.
- (b) In the sub-topic of *Forces in Equilibrium*, the teacher should assist students through investigation, group discussion, to apply the principle of moments and define states of equilibrium.
- (c) Teachers should provide tasks which demand the students to do mathematics so as to improve their competence in mathematical manipulation.
- (d) Teachers should lead students to prepare wall charts which show some of the formula used in calculations to make them remember easier.

**Table:** A Summary of Students' Performance (Question-Wise) in Engineering Science 2021.

S/N	Topic	Performance For Each Topic		Remarks
		Question Number	Percentage of students who scored 30% or more	
1.	Measurement, Simple Machine, Force, Friction, Heat, Sound, Electricity, Work, Energy and Power, and Turning Force	1	88.11	Good
2.	Simple Machine	8	71.07	Good
3.	Work, Energy and Power	9	60.13	Average
4.	Fluid Mechanics	7	50.51	Average
5.	Linear Motion	2 & 3	46.63	Average
6.	Electricity	10 & 4	42.41	Average
7.	Friction	5	37.18	Average
8.	Heat	6	24.27	Weak

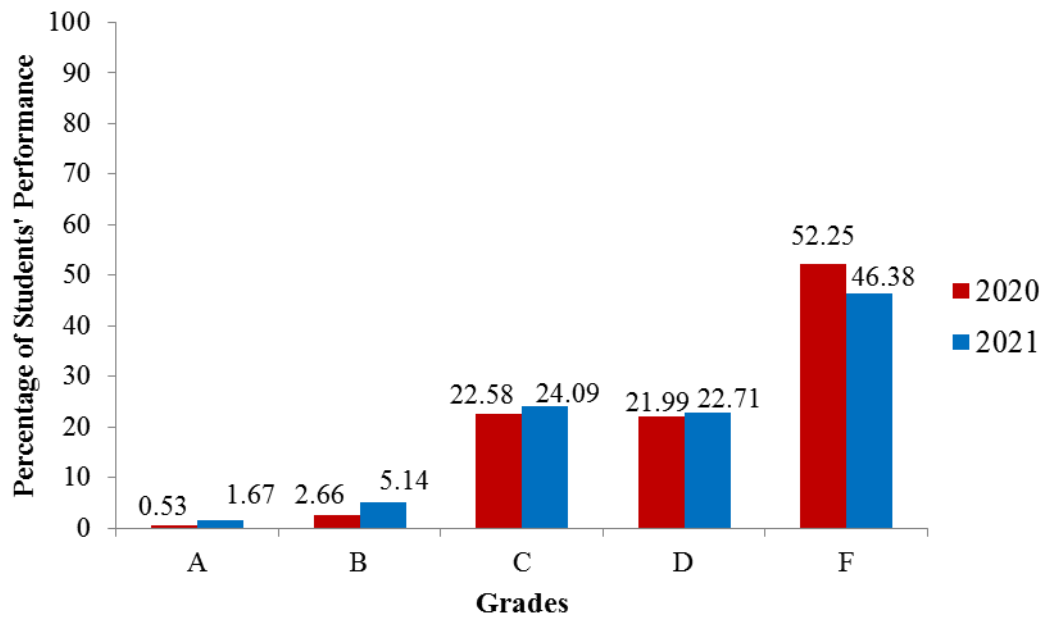

**Figure 12:** Comparisons of students' performance grade-wise for year 2020 and 2021

